

# ergotron®

---

## MX Wallmount LCD Arm

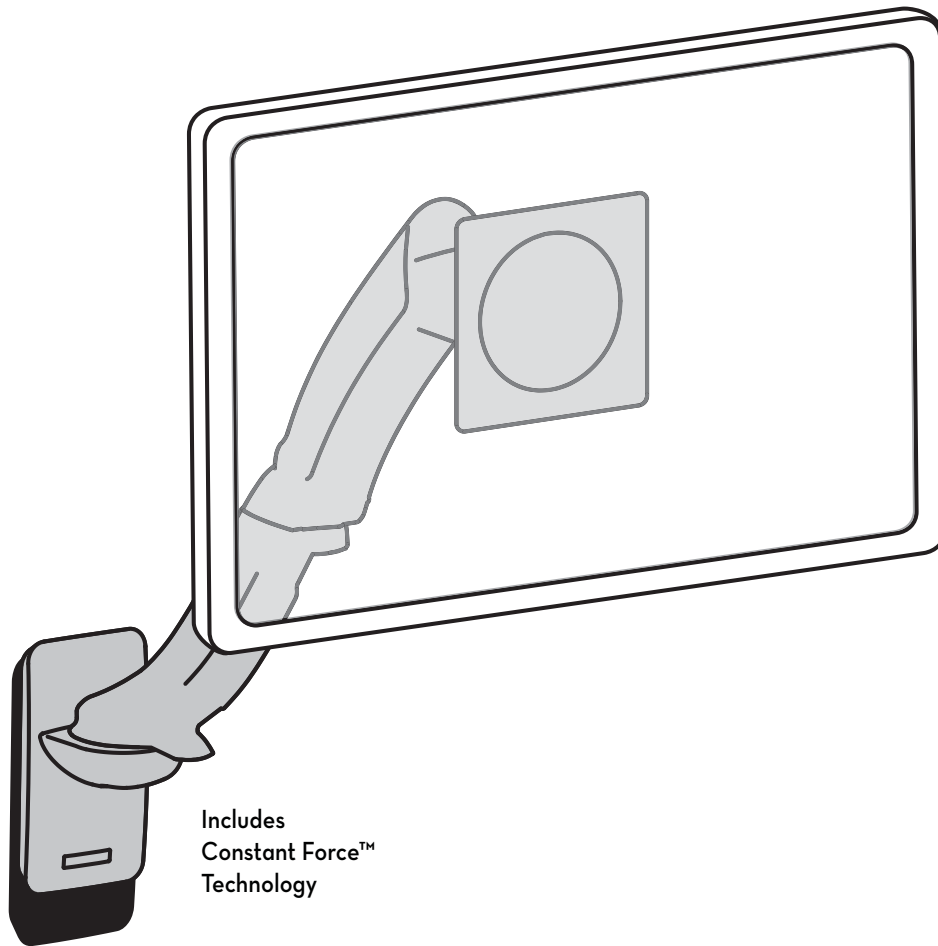

**EN** User Guide   **ES** Guía del usuario   **FR** Manuel de l'utilisateur   **DE** Benutzerhandbuch   **JA** ユーザーガイド



[www.ergotron.com](http://www.ergotron.com): English, Español, Français, Deutsch, Nederlands, Italiano, Türkçe, 日本語, 汉语

[www.ergotron.com](http://www.ergotron.com) | USA: 1-800-888-8458 | Europe: +31 (0)33-45 45 600 | China: 400-120-3051 | Japan: [japansupport@ergotron.com](mailto:japansupport@ergotron.com)

## Hazard Symbols Review

These symbols alert users of a safety condition that demands attention. All users should be able to recognize and understand the significance of the following Safety Hazards if encountered on the product or within the documentation. Children who are not able to recognize and respond appropriately to Safety Alerts should not use this product without adult supervision!

## Revisión de los símbolos de peligro

Estos símbolos alertan a los usuarios sobre un tema de seguridad que requiere su atención. Todos los usuarios deben poder reconocer y comprender el significado de los siguientes riesgos de seguridad si los ve en el producto o en la documentación. Los niños que no puedan reconocer y responder de forma adecuada a las alertas de seguridad no deben utilizar este producto sin la supervisión de un adulto.

## Examen des symboles de danger





Ces symboles avertissent les utilisateurs de conditions de sécurité nécessitant leur attention. Les utilisateurs doivent être en mesure de reconnaître et de comprendre ce que signifient les risques pour la sécurité suivants s'ils les voient sur le produit ou dans la documentation du produit. Les enfants qui ne peuvent pas reconnaître ni répondre correctement aux avertissements de sécurité ne doivent pas utiliser le produit sans la supervision d'un adulte !

## Überblick über die Gefahrensymbole

Diese Symbole machen den Benutzer auf einen sicherheitsgefährdenden Zustand aufmerksam, der behoben werden muss. Alle Benutzer sollten die folgenden Gefahrensymbole am Produkt bzw. in der Dokumentation erkennen und ihre Bedeutung verstehen können. Kinder, die Sicherheitswarnungen nicht verstehen und angemessen darauf reagieren können, dürfen dieses Produkt nur unter Aufsicht durch Erwachsene benutzen!

## 危険記号の説明

これらの記号は、ユーザーが注意すべき安全面の条件について警告するものです。製品またはドキュメントで次のような安全上の問題に直面した際、その重大さを認識して理解できる必要があります。安全上の注意を認識し、適切に対応できない子供が本製品を使用する場合は、大人の監督が必要です。

Symbol Símbolo Symbole Symbol 記号	Signal Word Símbolo Mot signal Signalwort 記号が表す言葉	Level of Hazard Nivel de riesgo Niveau de danger Gefahrenstufe 危険レベル
	NOTE NOTA REMARQUE HINWEIS 注	A NOTE indicates important information that helps you make better use of this product. Una NOTA presenta información importante que le ayudará a utilizar mejor este producto. Une REMARQUE indique des informations importantes destinées à vous aider à mieux utiliser de ce produit. Ein HINWEIS verweist auf wichtige Informationen, mit deren Hilfe Sie dieses Produkt besser nutzen können. 注は、本製品をより良く使用するための重要な情報です。
	CAUTION PRECAUCIÓN ATTENTION VORSICHT 注意	A CAUTION indicates either potential damage to hardware or loss of data and tells you how to avoid the problem. La PRECAUCIÓN indica la probabilidad de dañar el hardware o de perder datos y le señala la forma de evitar el problema. La mention ATTENTION indique la possibilité de dommages matériels ou de perte de données ainsi que la manière d'éviter le problème. Der Hinweis VORSICHT verweist auf potenzielle Hardwareschäden oder Datenverluste und informiert Sie darüber, wie Sie das Problem vermeiden können. 注意は、ハードウェアの損傷やデータ損失の可能性を示しており、問題を回避する方法も説明されています。
	WARNING ADVERTENCIA AVERTISSEMENT ACHTUNG 警告	A WARNING indicates either potential for property damage, personal injury, or death. Una ADVERTENCIA indica la probabilidad de daños materiales, lesiones personales o muerte. Un AVERTISSEMENT indique la possibilité de blessures personnelles potentiellement mortelles et de dommages matériels. Der Hinweis ACHTUNG verweist auf potenzielle Sachschäden oder Verletzungen bis hin zum Tod. 警告は、機器の損傷や人体の怪我を引き起こしたり、死に至らしめる可能性がある事態であることを示しています。
	ELECTRICAL ELÉCTRICO ÉLECTRIQUE ELEKTRIK 電気	An Electrical indicates an impending electrical hazard which, if not avoided, may result in personal injury, fire and/or death. Eléctrico indica un peligro eléctrico inminente que, si no se evita, puede dar lugar a lesiones personales, incendios y/o la muerte. Un symbole électrique signale une situation électrique potentiellement dangereuse qui, si elle n'est pas évitée, risque d'entraîner des blessures potentiellement mortelles et des incendies. Der Hinweis ELEKTRIK verweist auf eine drohende elektrische Gefahr die, wenn sie nicht vermieden wird, Verletzungen, einen Brand und/oder den Tod zur Folge haben kann. 電気は、回避しないと怪我、火災、死亡の恐れがある切迫した電気に関連する危険を示します。

# Safety Seguridad Sécurité Sicherheit 安全性



Important! You will need to adjust this product after installation is complete. Make sure all your equipment is properly installed on the product before attempting adjustments. This product should move smoothly and easily through the full range of motion and stay where you set it. If movements are too easy or difficult or if product does not stay in desired positions, follow the adjustment instructions to create smooth and easy movements. Depending on your product and the adjustment, it may take many turns to notice a difference. Any time equipment is added or removed from this product, resulting in a change in the weight of the mounted load, you should repeat these adjustment steps to ensure safe and optimum operation.

Importante! Tendrá que ajustar este producto una vez que haya terminado la instalación. Asegúrese de que todo su equipo esté instalado correctamente en el producto antes de intentar llevar a cabo algún ajuste. Este producto debe poder moverse de manera fácil y firme dentro de la amplitud de movimiento permitida y mantenerse donde usted lo fije. Si los movimientos son demasiado fáciles o difíciles o si el producto no se mantiene en las posiciones deseadas, siga las instrucciones de ajuste para conseguir movimientos suaves y fáciles. Dependiendo del producto y el ajuste, es posible que deba hacer muchos intentos hasta poder observar la diferencia. Cada vez que añada o retire equipos de este producto y que produzca un cambio en el peso de la carga, debe repetir estos pasos de ajuste para garantizar un funcionamiento seguro y óptimo.

Important! Vous devez ajuster le produit une fois l'installation terminée. Assurez-vous que l'équipement est correctement installé sur le produit avant de procéder aux ajustements. Ce produit doit pouvoir être déplacé sans difficulté sur toute la plage de mouvement et rester immobilisé à l'endroit où il est réglé. Si le mouvement est trop facile ou trop difficile, ou si le produit ne reste pas dans les positions souhaitées, procédez selon les instructions de réglage pour harmoniser les mouvements. En fonction de votre produit et du réglage, plusieurs tours peuvent s'avérer nécessaire pour remarquer la différence. Chaque fois qu'une pièce d'équipement est ajoutée ou retirée de ce produit, affectant en conséquence le poids de la charge montée, vous devez répéter ces étapes de réglage afin de garantir une utilisation sécurisée et optimale du produit.

Wichtig! Sie müssen dieses Produkt nach dem Zusammenbau entsprechend einstellen. Achten Sie darauf, dass alle Ihre Geräte richtig auf dem Produkt installiert wurden, bevor Sie irgendwelche Einstellungen vorzunehmen versuchen. Dieses Produkt sollte sich in seinem gesamten Bewegungsbereich ruckfrei und ohne Schwierigkeiten bewegen lassen und an der Stelle bleiben, an der es abgestellt wird. Wenn die Bewegungen zu leicht oder nur mit großer Anstrengung durchgeführt werden können oder das Produkt nicht in der vorgesehenen Position bleibt, beachten Sie die Einstellanleitung, um ruckfreie und einfache Bewegungen zu ermöglichen. Je nach Ihrem Produkt und der jeweiligen Einstellung können zahlreiche Manipulationen erforderlich sein, bevor Sie einen Unterschied feststellen. Zur Sicherstellung einer sicheren und optimalen Produktfunktion sollten Sie diese Einstellschritte immer dann durchführen, wenn Geräte hinzugefügt oder entfernt werden, was eine Veränderung der Traglast zur Folge hat.

重要! 本製品は取り付け後に調整する必要があります。調整を行う前に、すべての機器が本製品に適切に取り付けられていることを確認してください。本製品は可動範囲内でスムーズかつ簡単に動く必要があり、選定した位置にしっかり固定されなければなりません。製品が簡単に動きすぎる場合、動きがぎこちない場合、あるいは目的の位置に固定されない場合は、説明書に従いスムーズに動くように調整してください。お使いの製品や調整によっては、違いがはっきりするまで何回か回さなければならないこともあります。本製品に機器を追加したり、機器を取り外したことで積載重量が変わった場合は、安全かつ最適な操作を実現するために調節手順を繰り返してください。



Warning: Because mounting surface materials can vary widely, it is imperative that you make sure mounting surface is strong enough to handle mounted product and equipment.

Advertencia: Dado que los materiales de la superficie de montaje pueden variar enormemente, es imprescindible que se cerciore de que la superficie sea lo suficientemente resistente como para sostener el equipo y el producto montados.

Avertissement : Dans la mesure où les matériaux des surfaces de montage varient, vous devez impérativement vous assurer que la surface est suffisamment solide pour supporter le produit et l'équipement monté.

Warnung: Weil die Materialien der Befestigungsflächen stark variieren können, müssen Sie unbedingt gewährleisten, dass die Befestigungsfläche stark genug ist, um das montierte Produkt und die Ausrüstung zu tragen.

警告: 取り付け表面の材質にはさまざまな種類があるため、取り付け表面が取り付け製品や器具に対応した強さであることを必ず確認してください。



Caution:

To avoid the potential to pinch cables it is important to follow the cable routing instructions in this manual. Failure to follow these instructions may result in equipment damage or personal injury.

Precaución:

Para evitar la posibilidad de que se doblen los cables, es importante seguir las instrucciones de organización de los cables de este manual. En caso de no respetar estas instrucciones, podrían producirse daños en el equipo o lesiones físicas.

Attention :

Pour éviter de risquer de pincer les câbles, il est important de suivre les instructions d'acheminement des câbles de ce manuel. Le non-respect de cette consigne peut entraîner des dommages matériels et/ou des blessures.

Vorsicht:

Damit keine Kabel eingeklemmt werden können, müssen Sie die Anweisungen zur Kabelführung in diesem Handbuch einhalten. Ein Missachten dieser Anweisungen kann zu Geräteschäden oder Verletzungen führen.

注意:

ケーブルの挟まりを防ぐため、必ず本マニュアルのケーブル配線手順に従ってください。この指示に従わないと、機器の損傷や怪我を招く恐れがあります。

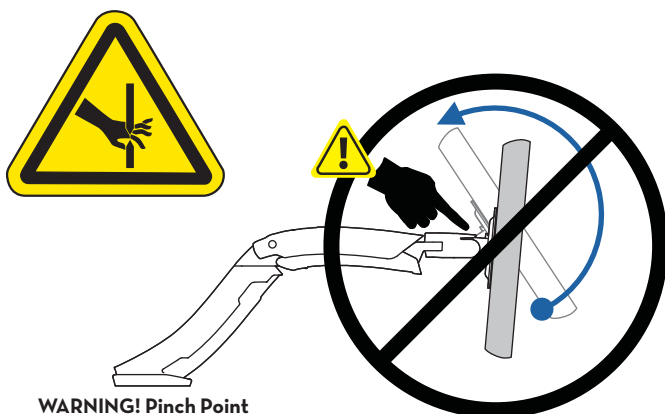

**WARNING! Pinch Point**

**ADVERTENCIA: Peligro de pellizco**

**AVERTISSEMENT! Point de pincement**

**WAARSCHUWING! Afknelpunt**

警告: ピンチポイントです。



**EN** **WARNING! Stored Energy Hazard:** The arm mechanism is under tension and will move up rapidly, on its own, as soon as attached equipment is removed. For this reason, **DO NOT** remove equipment unless the arm has been moved to the highest position! Failure to follow this instruction may result in serious personal injury and/or equipment damage!

**ES** **ADVERTENCIA:** Riesgo de energía almacenada: El mecanismo del brazo está bajo tensión y se moverá rápidamente hacia arriba, por sí mismo, tan pronto como se retire el equipo acoplado. Por ello, **NO** retire el equipo a menos que esté colocado en su posición más elevada. El incumplimiento de esta instrucción puede provocar lesiones personales graves y dañar el equipo.

**FR** **AVERTISSEMENT! Risque d'énergie accumulée :** Le mécanisme du bras est sous tension et se lèvera rapidement, tout seul, dès que le matériel est retiré. Pour cette raison, **NE PAS** retirer votre matériel à moins que le bras n'ait été mis à la position la plus élevée ! Risque de blessure corporelle et/ou d'endommagement du matériel en cas de non-respect de cette instruction !

**DE** **WARNUNG!** Gefährdung durch gespeicherte Energie: Der Arm-Mechanismus der Arbeitsfläche steht unter Spannung und bewegt sich von allein und schnell nach oben, sobald das befestigte Gerät abgenommen wird. Entfernen Sie aus diesem Grund die Geräte nur, wenn sich der Arm auf der höchsten Position befindet! Eine Missachtung dieser Anweisung kann zu ernsthaften Verletzungen und/oder Beschädigungen am Gerät führen.

**JA** 警告: 蓄積エネルギーの危険: アームメカニズムには張力が作用しており、付属機器を取り外すと自動的に素早く上に跳ね上がります。そのため、付属機器を取り外す前にアームが一番上の位置に移動してください。この指示を無視すると、重大な人体への傷害や機器の損傷を招く恐れがあります。

## Features & Specifications

## Características y especificaciones técnicas

## Caractéristiques et spécifications

## Produkteigenschaften & Technische Daten

## 特長と仕様



**14 - 30 lbs. (6.35 - 13.61 kg)**

CAUTION: DO NOT EXCEED MAXIMUM LISTED WEIGHT CAPACITY. SERIOUS INJURY OR PROPERTY DAMAGE MAY OCCUR!

PRECAUCIÓN: NO SUPERE LA CAPACIDAD DE PESO MÁXIMA INDICADA. PODRÍA OCURRIR DAÑOS MATERIALES GRAVES O LESIONES FÍSICAS.

ATTENTION : NE PAS DÉPASSER LA CAPACITÉ NOMINALE MAXIMALE MENTIONNÉE. DE SÉRIEUSES BLESSURES OU DES DOMMAGES MATÉRIELS POURRAIENT SE PRODUIRE !

VORSICHT: DIE ANGEGEBENE MAXIMALE TRAGFÄHIGKEIT NICHT ÜBERSCHREITEN. DIES KANN SCHWERE VERLETZUNGEN ODER SACHSCHÄDEN ZUR FOLGE HABEN!

注意:積載物は記載の最大積載重量を超えてはなりません。重大な人体の怪我や機器の損傷を招く恐れがあります。

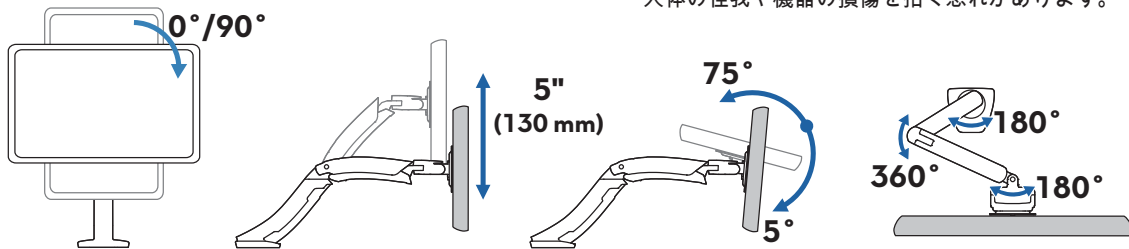
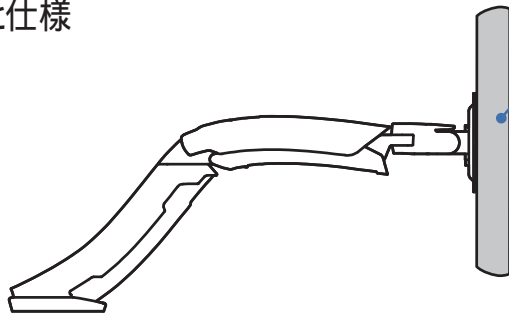

## Components











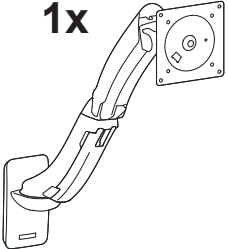



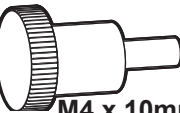

## Componentes

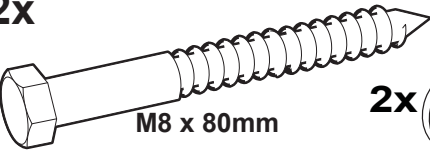
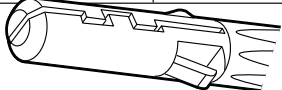
## Composants

## Komponenten

## 構成部品

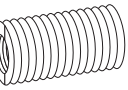

	A	B	C	D	E
1	1x 	1x 	1x  M3 x 6mm	1x  4mm	2x  2.5mm
2	4x  M4 x 10mm	4x  M4 x 10mm	4x  M4 x 12mm	4x  M5 x 7mm	4x  M5 x 12mm
3	2x  M8 x 80mm		2x 	1x  1/8"	
4	2x  8mm		4x 	4x  10-24 x 3/8"	
5	4x 	4x  M6 x 12mm	4x  M8M5 Converter Conversor M8M5 Convertisseur M8M5 M8M5-Konverter M8M5サイズ変換ネジ	4x  M5 x 20mm	

Tools Needed  
 Herramientas necesarias  
 Outillage requis  
 Benötigtes Werkzeug  
 必要なツール

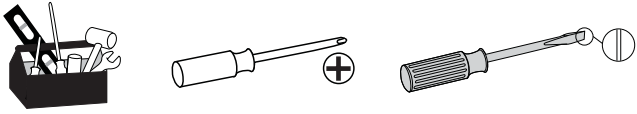

Concrete  
 Concreto  
 Béton  
 Massivbeton  
 コンクリート

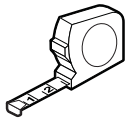
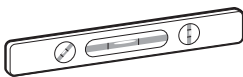
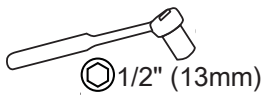
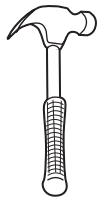
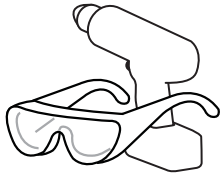
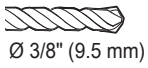
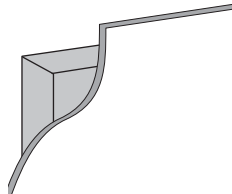

Wood  
 Madera  
 Bois  
 Solide Holzbalkenträger  
 木

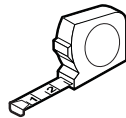
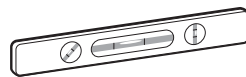
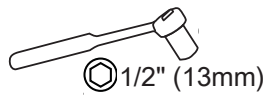
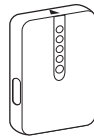
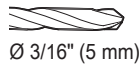
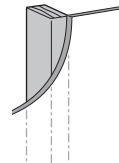

# 1 Mounting Height for Ergonomic Workstation

This mounting height is a recommendation for an ergonomic workstation that accommodates user heights of 5'4"-5'9" (162.5-175cm) when set up for standing and user heights of 5'3"-5'11" (160-180cm) when set up for sitting.

If user heights are different than this, you should change mounting height to accommodate user heights. (Change mounting height one inch for every one inch difference in user heights).

## Altura de montaje de la estación de trabajo ergonómica

Se recomienda esta altura de montaje para una estación de trabajo ergonómica que se adapte a estaturas de usuario de 5'4"-5'9" (162.5-175cm) para trabajar de pie y de 5'3"-5'11" (160-180cm) para trabajar sentado.

Si la estatura del usuario es diferente, se debe modificar la altura de montaje de modo que se adapte a la estatura del usuario. (Cambiar la altura de montaje una pulgada por cada pulgada de diferencia en la estatura del usuario).

## Hauteur de montage pour un poste de travail ergonomique

Cette hauteur de montage est une recommandation pour un poste de travail ergonomique pour les utilisateurs mesurant entre 5'4"-5'9" (162.5-175cm) en configuration debout et entre 5'3"-5'11" (160-180cm) en configuration assise.

Si la taille de l'utilisateur se situe en dehors de ces fourchettes, vous devez modifier la hauteur de pose pour l'adapter à cette taille. (Changez la hauteur de pose d'un centimètre pour chaque centimètre de différence de taille de l'utilisateur).

## Montagehöhe für ergonomischen Arbeitsplatz

Diese Montagehöhe wird für einen ergonomischen Arbeitsplatz empfohlen, der für Benutzer mit einer Körpergröße zwischen 5'4"-5'9" (162.5-175cm) (bei einer Einrichtung fürs Arbeiten im Stehen) und zwischen 5'3"-5'11" (160-180cm) (bei einer Einrichtung fürs Arbeiten im Sitzen) geeignet ist.

Wenn die Körpergröße des Benutzers nicht in diesem Bereich liegt, sollten Sie die Montagehöhe an die Körpergröße des Benutzers anpassen. (Verändern Sie die Montagehöhe um jeweils 2,5 cm pro 2,5 cm Unterschied bei der Körpergröße.)

## 人間工学ワークステーションの取り付け高さ

この取り付け高さは、立位向けに設定する場合は身長 5'4"-5'9" (162.5-175cm) のユーザー、座位向けに設定する場合は身長 5'3"-5'11" (160-180cm) のユーザーが使用する人間工学ワークステーションを対象とした推奨値です。

ユーザーの身長がこの範囲外の場合、そのユーザーの身長に合わせて取り付け高さを調節する必要があります (ユーザーの身長がこれより 3cm 高い/低い場合は、取り付け高さを 3cm 高く/低く調節します)。

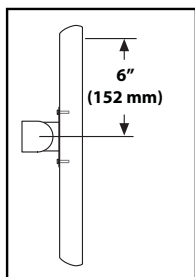

Mounting height assumes there is a 6" (152 mm) distance between the center of your monitor mounting holes and the top of the screen. If your distance is smaller, you should increase mounting height accordingly, if your distance is larger, you should decrease your mounting height accordingly.

Para la altura de montaje se asume que hay una distancia de 152 mm (6 pulgadas) entre el centro de los orificios de montaje del monitor y la parte superior de la pantalla. Si la distancia es menor, se debe aumentar la altura de montaje según corresponda; si la distancia es mayor, se debe disminuir la altura de montaje en consecuencia.

Cette hauteur de montage suppose une distance de 152 mm entre le centre des trous de montage de votre moniteur et le haut de l'écran. Si la distance est plus petite, vous devrez augmenter la hauteur de montage en conséquence; si la distance est plus grande, vous devez réduire la hauteur de montage en conséquence.

Bei der Bestimmung der Montagehöhe wird von einem Abstand von 152 mm (6") zwischen der Mitte der Monitormontagelöcher und der Oberkante des Bildschirms ausgegangen. Wenn der tatsächliche Abstand kleiner ist, sollten Sie die Montagehöhe entsprechend vergrößern; wenn er größer ist, sollten Sie ihn entsprechend verringern.

取り付け高さは、モニター取り付け穴の中心から画面の上端までに 152mm (6") の距離があることを前提としています。この距離がこれより近い場合はさらに高い位置に取り付ける、またこれより遠い場合はさらに低い位置に取り付ける必要があります。



Mounting Height for Ergonomic Workstation  
 Altura de montaje de la estación de trabajo ergonómica  
 Hauteur de montage pour un poste de travail ergonomique  
 Montagehöhe für ergonomischen Arbeitsplatz  
 人間工学ワークステーションの取り付け高さ

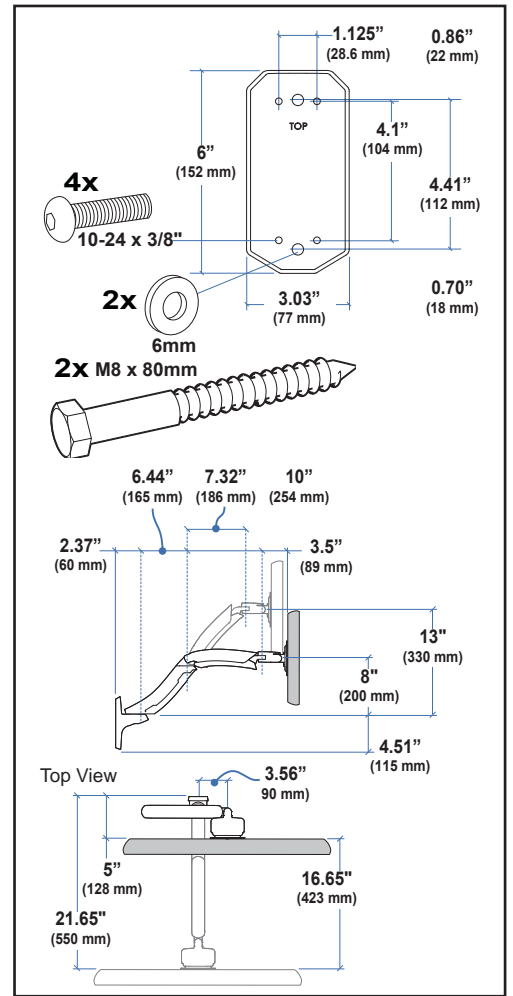
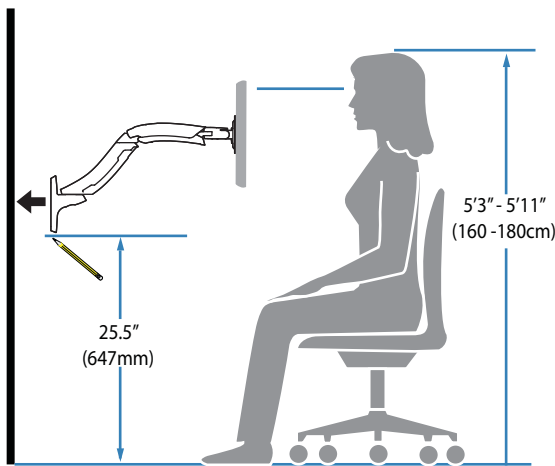
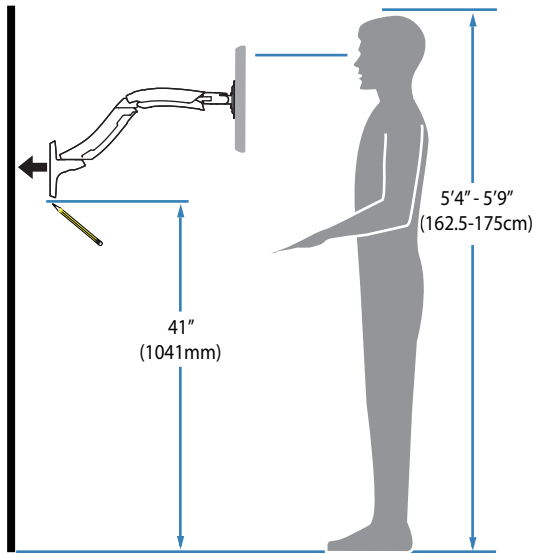

**Determine mounting location:**

Front view with arm pushed back against the wall.

**Determine el lugar de instalación:**

Vista frontal con el brazo retraído contra la pared.

**Déterminez l'emplacement de pose :**

Vue de face avec bras poussé contre le mur

**Montageposition bestimmen:**

Blick von vorne mit gegen die Wand gedrücktem Arm

**取り付け位置の決定:**

アームを壁側に引いた状態の正面図。

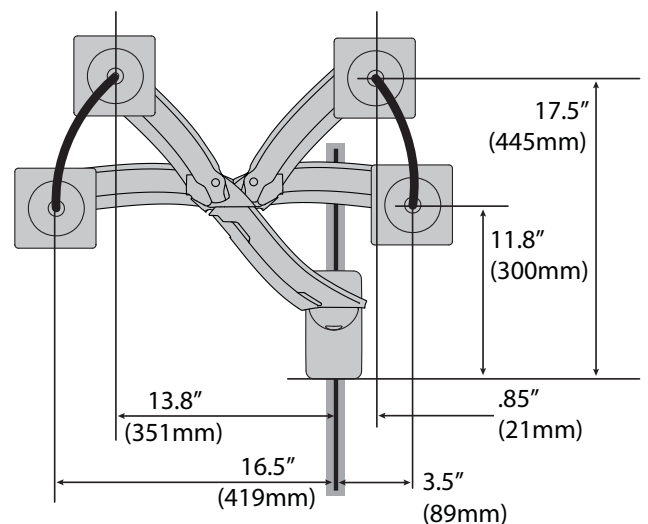



# 2

**Choose Mounting Method. Ergotron product. NOTE: Wall Track and Brackets sold separately.**  
**Elija el método de montaje. Producto Ergotron. Guía y soporte de pared Vendido por separado**  
**Choisissez une méthode de fixation. Produit Ergotron. Montant mural et fixation Vendu séparément**  
**Wählen Sie die Befestigungsmethode. Ergotron Produkt. Alu-Profilschiene und Bügel Separat erhältlich**  
**取り付け方法の選択. エルゴトロン製品. ウォールトラックおよびブラケット別売**

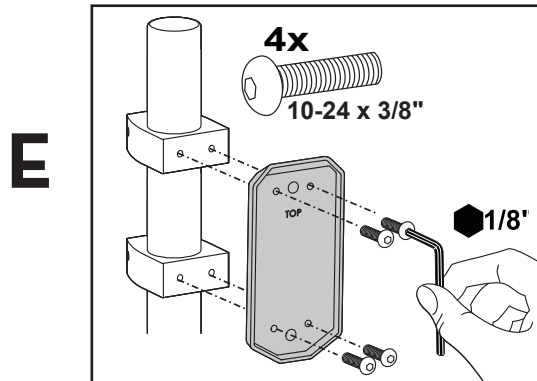
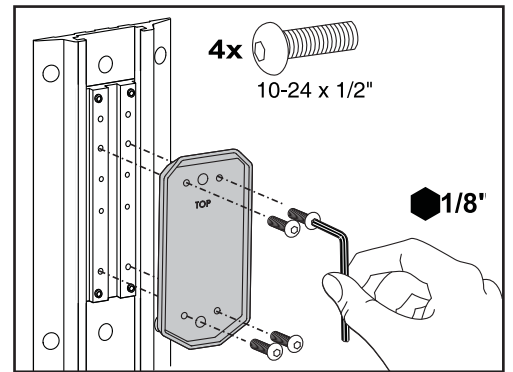
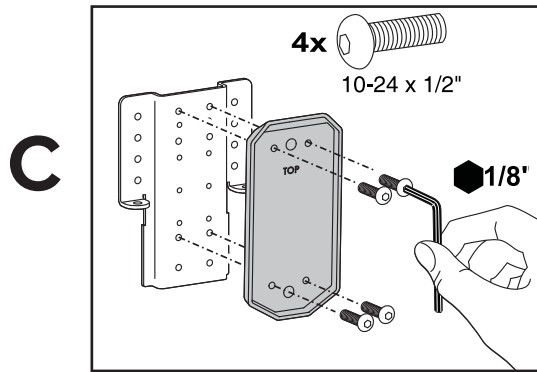
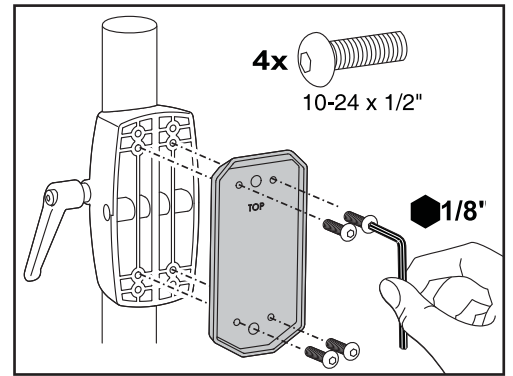
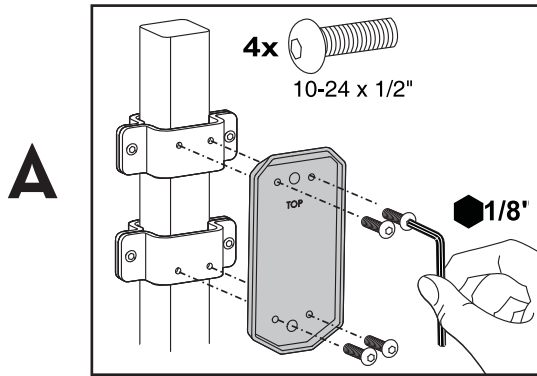

  
 When attaching to Pole Clamps, use 10-24 x 3/8" screws included with pole brackets, Do NOT use 10-24 x 1/2" screws

Atención: Cuando lo instale en abrazaderas para polo, use tornillos 10-24 x 3/8". No utilice tornillos 10-24 x 1/2"

Attention : pour une fixation sur tube, utilisez des vis 10-24 x 3/8". N'utilisez pas de vis 10-24 x 1/2".

Zur Montage an Befestigungsringen verwenden Sie bitte 10-24 x 3/8" Schrauben, KEINE 10-24 x 1/2" Schrauben.

ポール クランプに取付ける際、10-24 x 3/8" のネジを使い、10-24 x 1/2" のネジは使用しないでください。

## F

Concrete  
 Concreto  
 Béton  
 Massivbeton  
 コンクリート

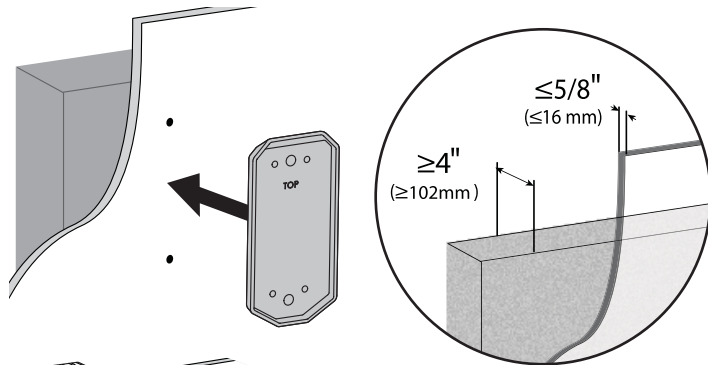

## G

Wood  
 Madera  
 Bois  
 Solide Holzbalkenträger  
 木

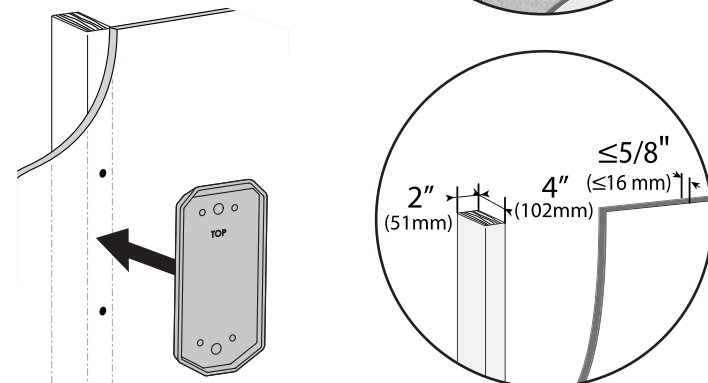

# 2 Concrete Concreto Béton Massivbeton コンクリート

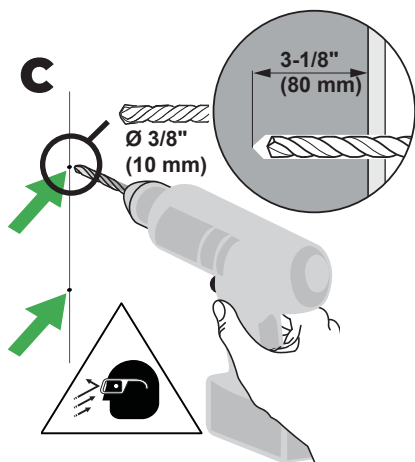
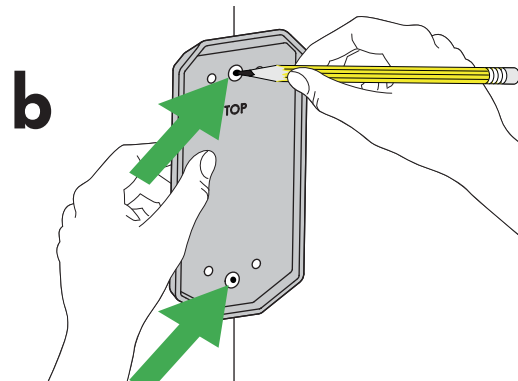
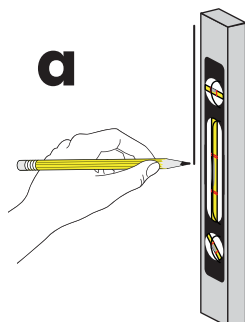
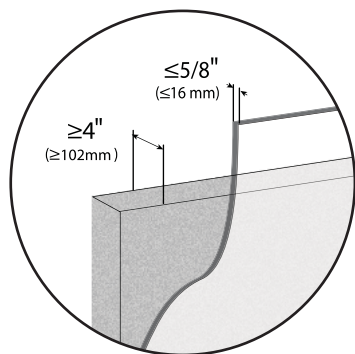

## WARNING:

Mounting holes must be at least 3-1/8" (80mm) deep and must be located within solid concrete, not mortar or covering material. If you drill into an area of concrete that is not solid, reposition mounting holes until both anchors can be fully inserted into solid concrete!

## AVISO:

Los taladros deben tener una profundidad mínima de 80 mm. y deben realizarse en la capa sólida de ladrillo u hormigón y no en el revestimiento o capa de enlucido. Si taladra en una zona poco sólida, coloque de nuevo los 2 huecos para el montaje de forma que queden dispuestos en una capa sólida.

## ATTENTION :

Les trous que vous allez percer doivent être d'une profondeur minimale de 80 mm et correctement placés dans le béton (pas dans les joints). Si vous percez dans une partie insuffisamment résistante, repositionnez la platine pour que les 2 trous soient tous situés dans le béton!

## ACHTUNG:

Die Bohrlöcher müssen mindesten 80 mm tief sein und sollten in Massivbeton gebohrt werden, nicht in Mörtel oder Abdeckmaterialien. Sollten Sie beim Bohren feststellen, dass Sie in Beton bohren, der Hohlräume enthält, so wiederholen Sie den Vorgang bis sich alle vier Bohrlöcher vollständig in massivem Beton befinden.

## 警告:

マウントホールは最低3-1/8" (80 mm) の深さがが必要です。外壁がモルタルやその他の材質で、内壁がコンクリートの壁にドリルで穴を開ける場合、両方のアンカーがコンクリート内壁に完全に挿入されるよう、マウントホールを再調整します。

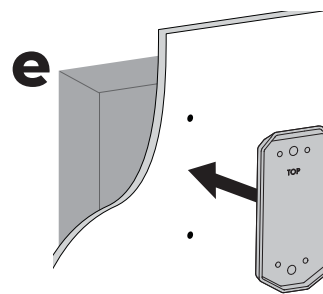
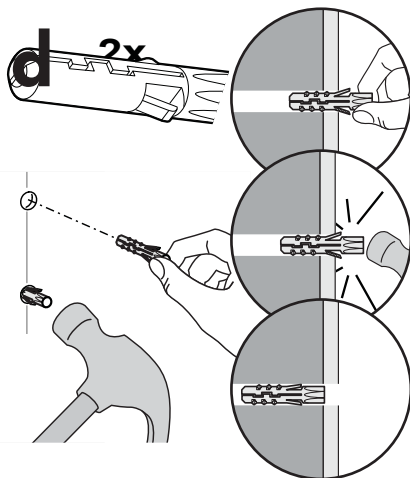

## WARNING:

Anchors that are not fully set in solid concrete will not support the applied load resulting in an unstable, unsafe condition which could lead to personal injury and/or property damage. Consult a construction professional if you have any doubt about what this means in regard to your particular situation.

## AVISO:

Los tacos deben introducirse por completo en el ladrillo u hormigón, pues de otro modo no soportarán el peso de su monitor, dando lugar a una instalación inestable e insegura que puede ocasionar lesiones personales y / o daños en el monitor y la pared. Consulte a un instalador profesional si tiene dudas al respecto de su caso particular.

## ATTENTION :

Des chevilles qui ne sont pas entièrement insérées dans le béton risquent de créer une faiblesse dans le montage et d'entraîner des dommages corporels et/ou matériels. En cas de doute, contactez un professionnel.

## ACHTUNG:

Verankerungen die sich in nicht vollständig massivem Beton befinden, werden das Gewicht der angehängten Last nicht tragen und zu einem instabilen, unsicheren Zustand führen, der zu Personen- und/oder Sachschaden führen kann.

## 警告:

アンカーがコンクリート内壁にしっかり収まっていない場合、加重重量をサポートできず、けが及び/または物的損害の原因となる不安定で危険な状況となりかねません。特定用途に壁の強度の良し悪しが懸念される場合は建設業者にご相談ください。

# 2

Wood  
Madera  
Bois  
Solide Holzbalkenträger  
木

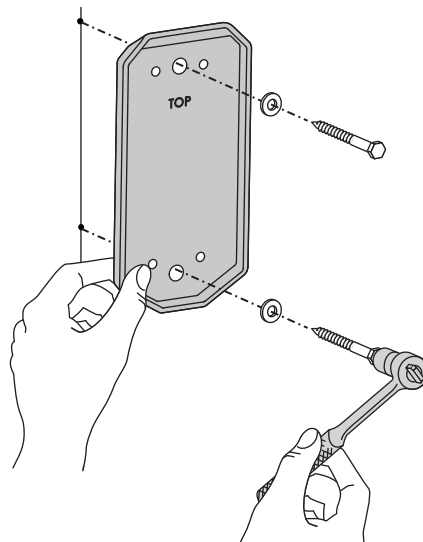
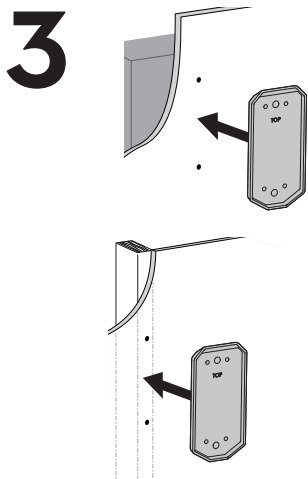
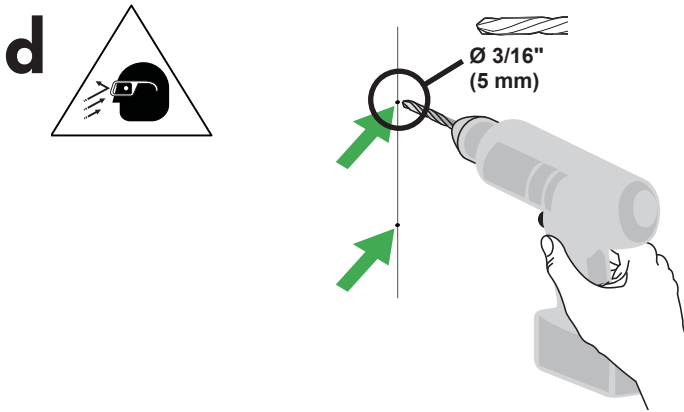
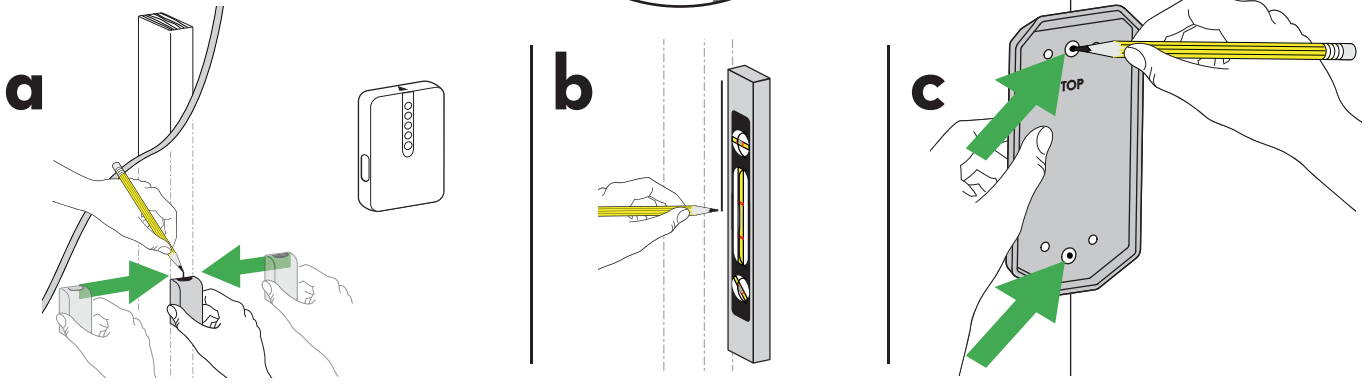
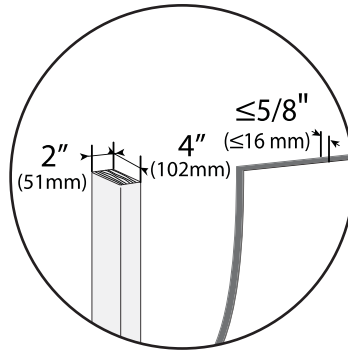

2x M8 x 80mm

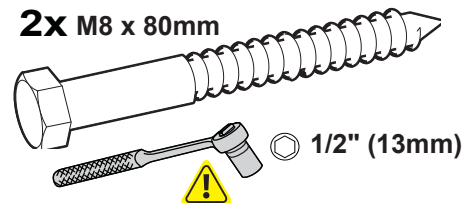

2x  
8mm

**CAUTION:** Make sure the wall mount bracket is level, flush and snug to the wall surface. **DO NOT OVERTIGHTEN THE BOLTS.**

**PRECAUCIÓN:** Asegúrese de que la fijación de la montura en pared está nivelada, iguálela y ajústela respecto a la pared. **NO RETIRAR ESTA ETIQUETA!**

**AVERTISSEMENT :** assurez vous que le support mural soit bien à plat et contre la surface du mur. **NE PAS SERRER EXCESSIVEMENT LES BOULONS.**

**VORSICHT:** Bitte versichern sie sich, dass die Wandhalterung gerade befestigt ist und dabei dicht and der Wand anliegt. **DIE SCHRAUBEN NICHT ZU STRAFF ANZIEHEN.**

注意：壁取り付けブラケットが壁の表面に水平に接触してぴったりおさまっているが確認してください。ボルトは締め付けすぎないようにしてください。

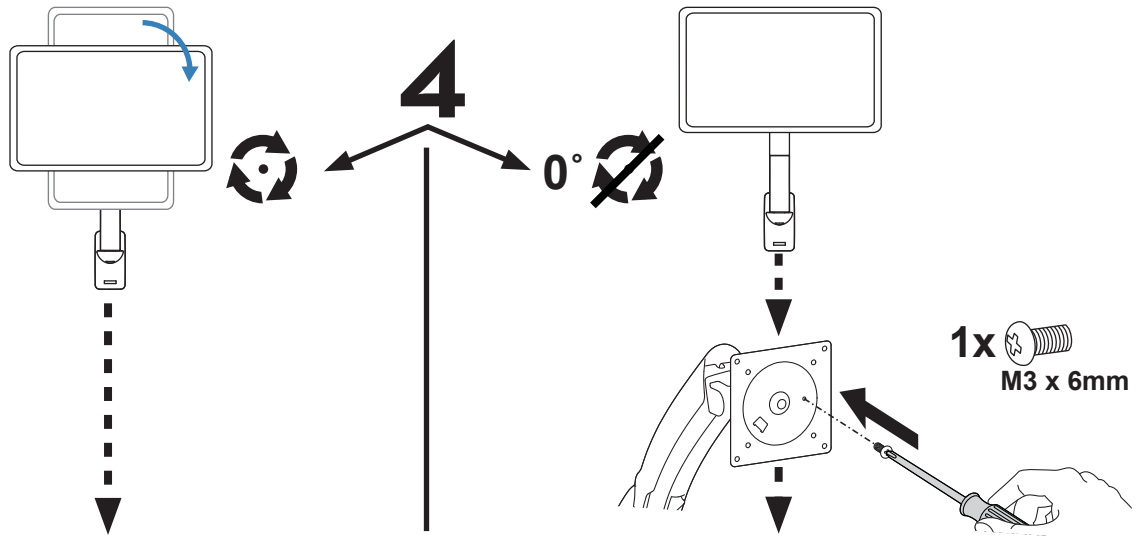

# 5

Check size of TV/Monitor hole pattern  
 Verifique el tamaño del patrón de orificios del TV/monitor  
 Repérez la disposition et l'écartement des trous du téléviseur ou de l'écran.  
 Größe des TV/Monitor-Lochmusters prüfen  
 テレビ/モニターの穴位置間隔を確認します

TV/Monitor Hole Pattern Sizes  
 Tamaños del patrón de orificios del TV/monitor  
 Disposition et écartement des trous pour TV/écran  
 TV/Monitor-Lochmustergrößen  
 テレビ/モニターの穴位置間隔

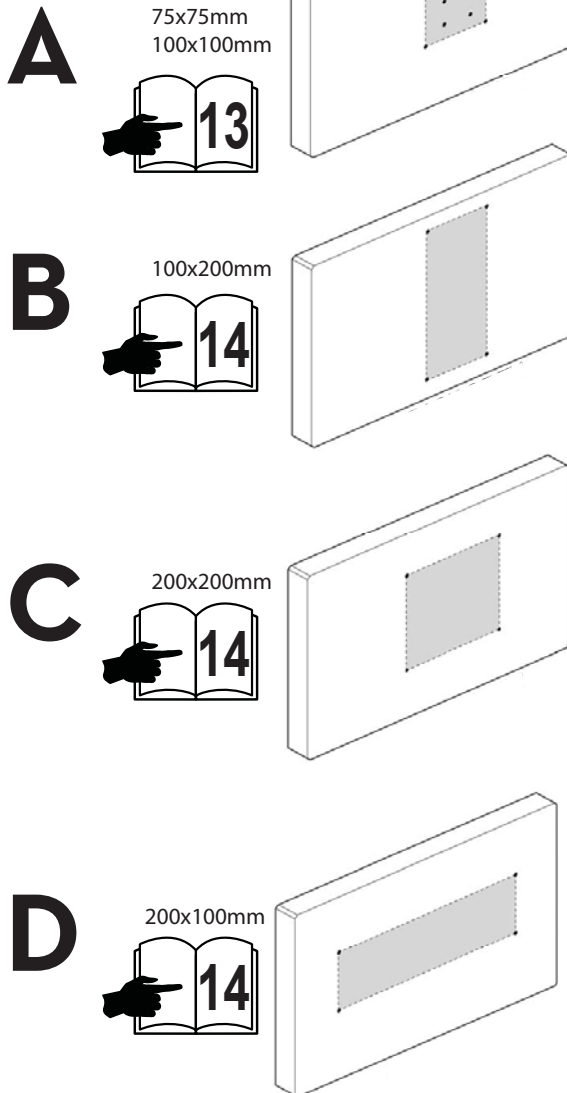

VESA Adapter Configurations  
 Configuraciones del adaptador VESA  
 Configurations pour Adaptateur VESA  
 VESA-Adapterkonfigurationen  
 VESAアダプタの構成

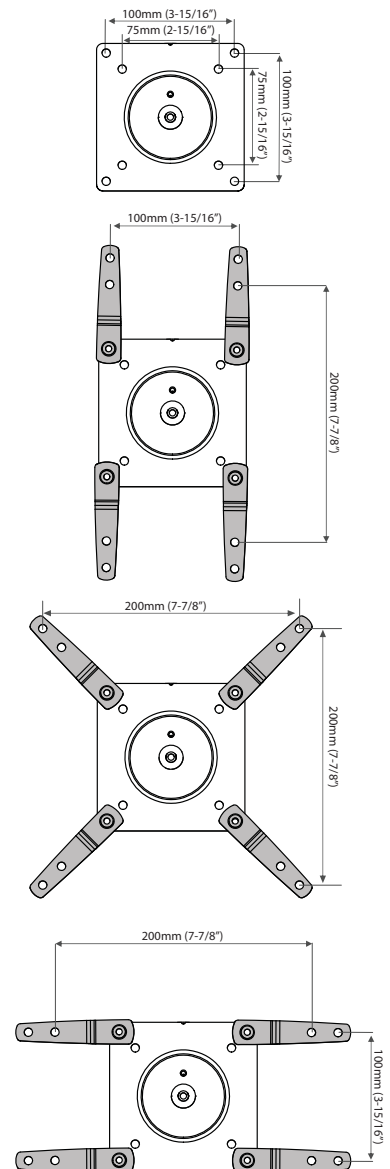

# A

Mount Type A TV/Monitor to Arm

Instale el TV/monitor tipo A en el brazo

Montage d'un téléviseur ou d'un écran de type A sur le bras

TV/Monitor vom Typ A am Arm befestigen.

タイプAのテレビ/モニターをアームに取り付ける

B, C, D  13

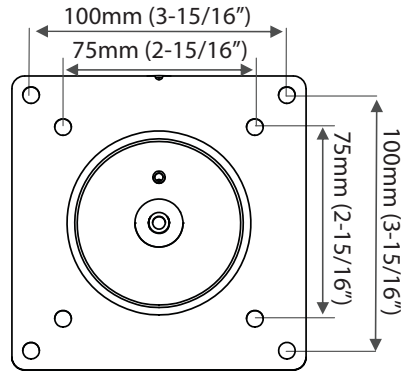

## 75 x 75mm

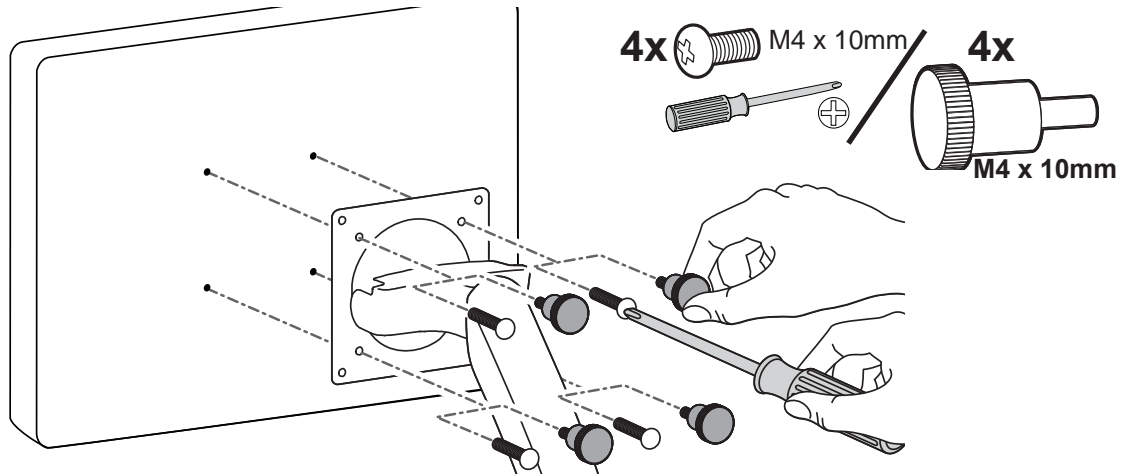
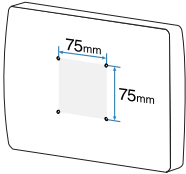

## 100 x 100mm

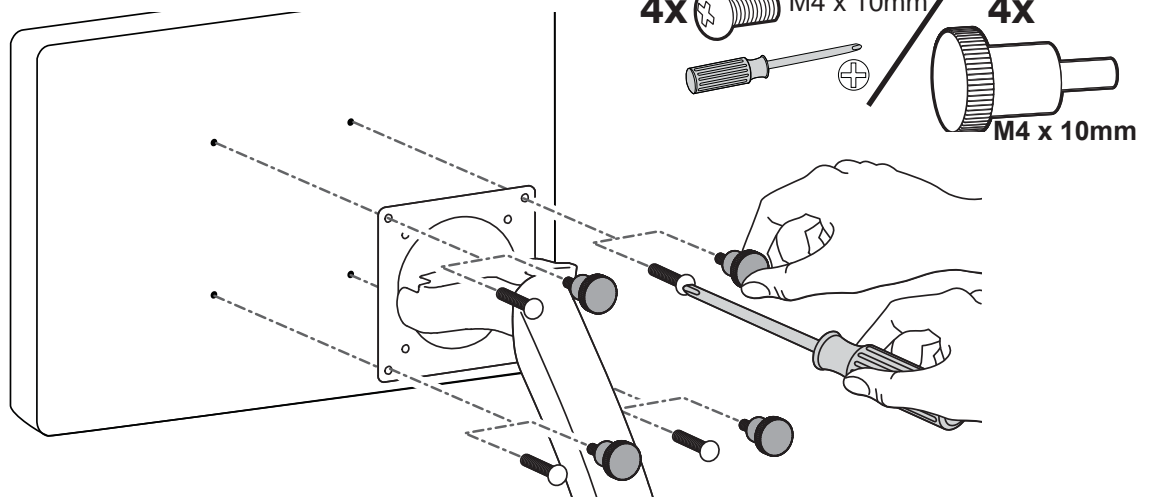
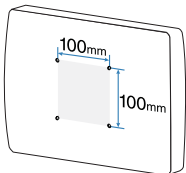

6  16

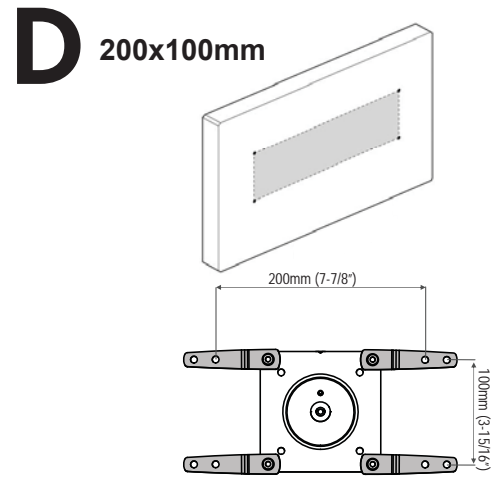
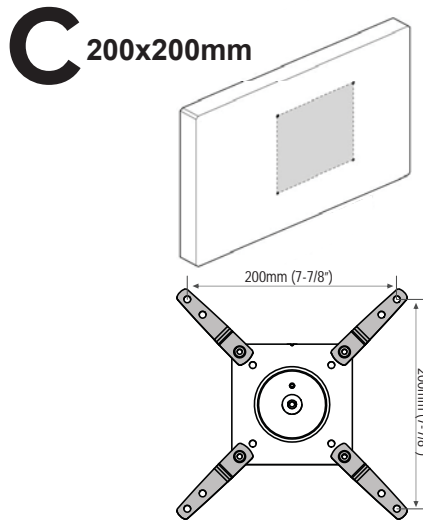
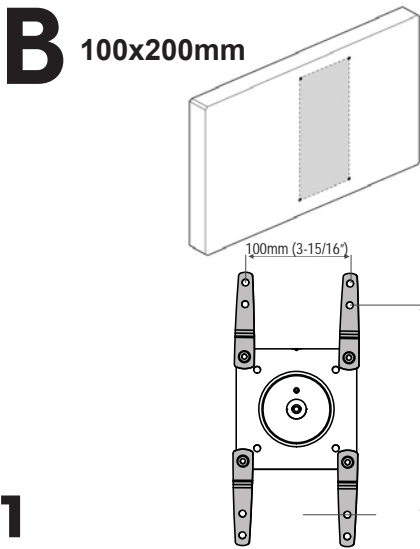

**1**

Mount VESA Adapters to Arm based on TV/Monitor hole pattern size (B, C, or D) .

Instale los adaptadores VESA en el brazo basándose en el tamaño del patrón de orificios del TV/monitor (B, C o D) .

Fixez les adaptateurs VESA au bras en fonction de la configuration et de l'écartement des trous pour TV/écran (B, C ou D) .

VESA-Adapter auf Basis der TV/Monitor-Lochmustergröße (B, C oder D) am Arm befestigen.

テレビ/モニターの穴位置間隔(BまたはC、D)に基づいてVESAアダプタをアームに取り付けます。

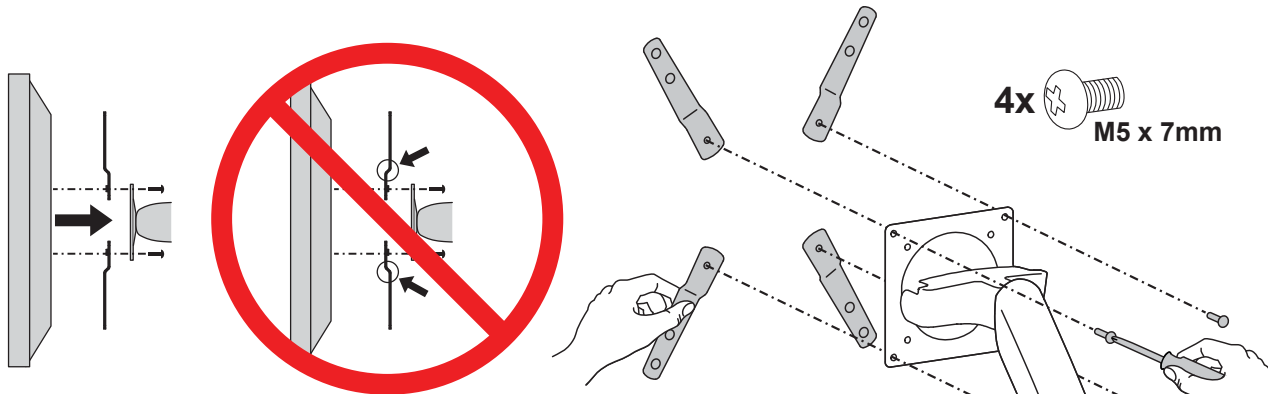

**2**

Mount Type B, C, or D TV/Monitor to Arm

Instale el TV/monitor tipo B, C o D en el brazo

Montage d'un téléviseur ou d'un écran de type B, C ou D sur le bras

TV/Monitor vom Typ B, C oder D am Arm befestigen.

タイプBまたはC、Dのテレビ/モニターをアームに取り付ける

**NOTE:** To reduce M8 holes for use with M5 screws, or if you have a model with Samsung holder rings, follow the **M8M5 KIT** instructions on the next page.

**NOTA:** Para reducir los orificios M8 cuando utilice tornillos M5, o si dispone de un modelo con aros de sujeción Samsung, siga las instrucciones del **KIT M8M5** de la siguiente página.

**REMARQUE :** Pour réduire les trous M8 afin d'y utiliser des vis M5, ou si vous avez un modèle avec des anneaux de support Samsung, suivez les instructions du kit **M8M5** à la page suivante.

**HINWEIS:** Um die M8-Lochgröße für den Gebrauch von M5-Schrauben zu verkleinern, oder wenn Ihr Modell Samsung-Halteringe verwendet, beachten Sie die Anleitung zum **M8M5-Satz** auf der nächsten Seite.

注: M8ネジ穴を縮小してM5ネジを使う場合、あるいは Samsungホルダーリングを使用するモデルの場合は、次のページのM8M5キットの取り付け方に従ってください。

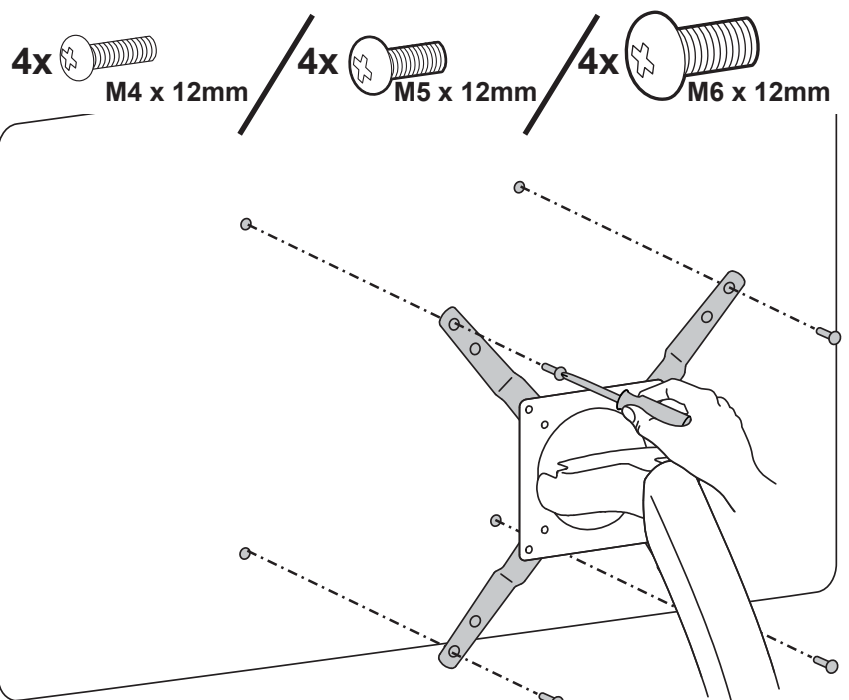

## M8M5 KIT Instructions

## M8M5 KIT Instructions Instrucciones del KIT M8M5

## Instructions du kit M8M5

## Anleitung zum M8M5-Satz

## M8M5キットの取り付け方

**NOTE:** Follow this step only if your TV/monitor has M8 holes which need to be reduced to M5.  
Install M8M5 reducer bushing to TV/Monitor and use M5 x 20 mm monitor screws to secure.

**NOTA:** Siga este paso solamente si su televisor/monitor cuenta con orificios M8 que requieran una reducción a M5.

Instálele el buje reductor M8M5 al televisor/monitor y emplee tornillos para monitor M5 x 20 mm para fijarlo.

**REMARQUE :** suivez cette étape uniquement si votre téléviseur ou écran est muni de trous M8 qui doivent être réduits à des M5.

Installez la douille de réduction M8M5 sur le téléviseur ou l'écran et utilisez les vis d'écran M5 x 20 mm pour le montage.

**HINWEIS:** Befolgen Sie diese Schritte nur dann, wenn Ihr Fernseher/Bildschirm mit M8-Löchern versehen ist, die auf M5 reduziert werden müssen.

Installieren Sie eine M8M5-Reduzierbuchse am Fernseher/Bildschirm und verwenden Sie zur Sicherung M5 x 20 mm Bildschirmschrauben.

注：テレビ/モニターに、M5に低減する必要があるM8穴がついている場合のみ、この手順に従ってください。

テレビ/モニターにM8M5レジューサーブッシュを取り付け、M5 x 20 mmモニターネジを使用して固定します。

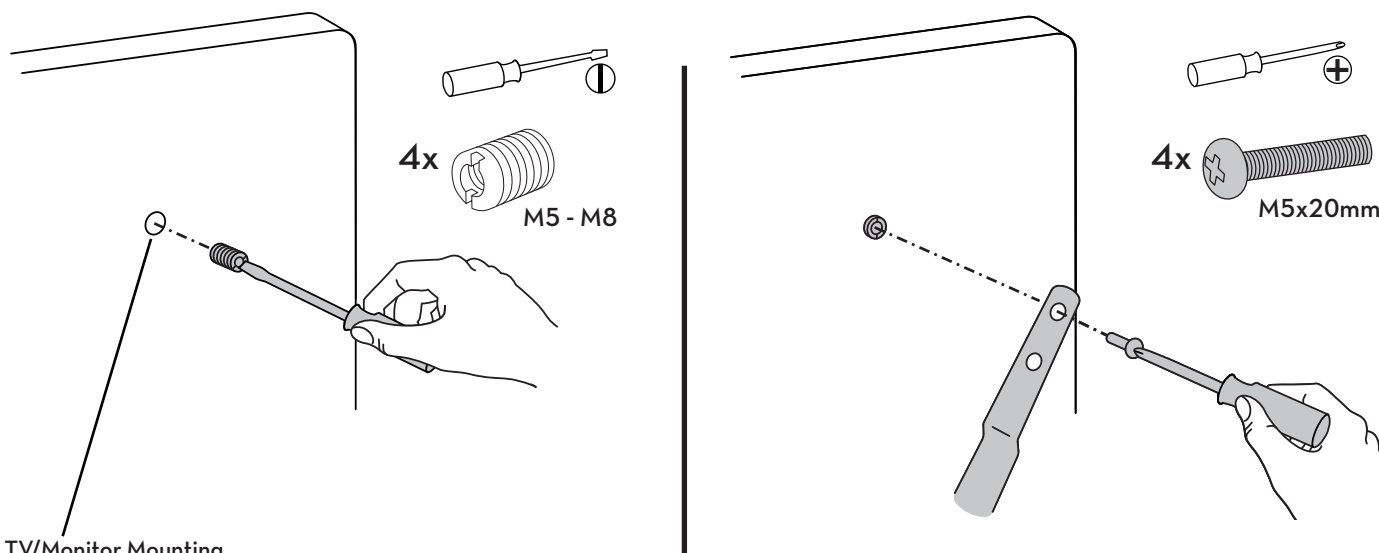

TV/Monitor Mounting  
M8 size hole

Orificio de tamaño M8 de montaje  
del TV/monitor.

Trou de montage de téléviseur/  
d'écran de taille M8

Lochgröße M8 für TV/Monitor-  
Befestigung

M8サイズのテレビ/モニター取り  
付け穴



## M8M5 KIT Instructions

## M8M5 KIT Instructions Instrucciones del KIT M8M5

## Instructions du kit M8M5

## Anleitung zum M8M5-Satz

## M8M5キットの取り付け方

**NOTE:** Follow this step only for Samsung models using the holder ring.

Install M8M5 reducer bushing to TV/Monitor then use M5 x 20 mm monitor screws and Samsung holder ring to secure.

**NOTA:** Siga este paso solamente en modelos Samsung empleando la arandela de soporte.

Instálele el buje reductor M8M5 al televisor/monitor y emplee tornillos para el monitor M5 x 20 mm y la arandela de soporte Samsung para fijar.

**REMARQUE :** suivez cette étape uniquement pour les modèles Samsung utilisant un anneau de support.

Installez la douille de réduction M8M5 sur le téléviseur ou l'écran, puis utilisez les vis d'écran M5 x 20 mm et l'anneau de support Samsung pour le montage.

**HINWEIS:** Befolgen Sie die Schritte nur bei Samsung-Modellen unter Verwendung des Halteringes.

Installieren Sie eine M8M5-Reduzierbuchse am Fernseher/Bildschirm und verwenden Sie zur Sicherung M5 x 20 mm Bildschirmschrauben sowie den Samsung-Haltering.

注：ホルダーリングを使用するSamsungモデルの場合のみ、以下の手順に従ってください。テレビ/モニターにM8M5レジューサーブッシュを取り付けてから、M5 x 20 mmモニターネジとSamsungホルダーリングを使用して固定します。

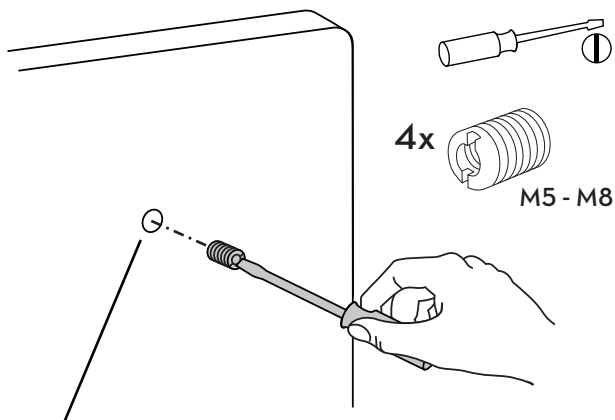

TV/Monitor Mounting  
M8 size hole

Orificio de tamaño M8 de montaje del TV/monitor.

Trou de montage de téléviseur/d'écran de taille M8

Lochgröße M8 für TV/Monitor-Befestigung

M8サイズのテレビ/モニター取り付け穴

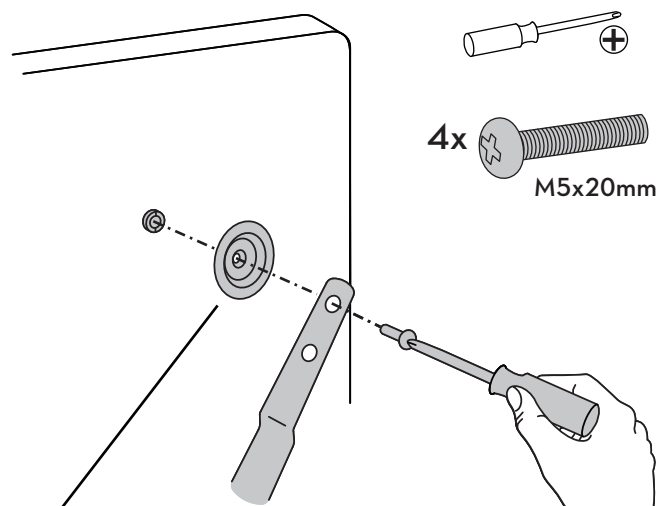

Holder Ring  
(Not included \*Samsung Only)

Aro de sujeción (no incluido \* Solo Samsung )

Anneau de support (non inclus \* Samsung uniquement)

Haltering (nicht inbegriffen \*nur Samsung)

ホルダーリング(含まれていません。\*Samsungのみ)

6

a

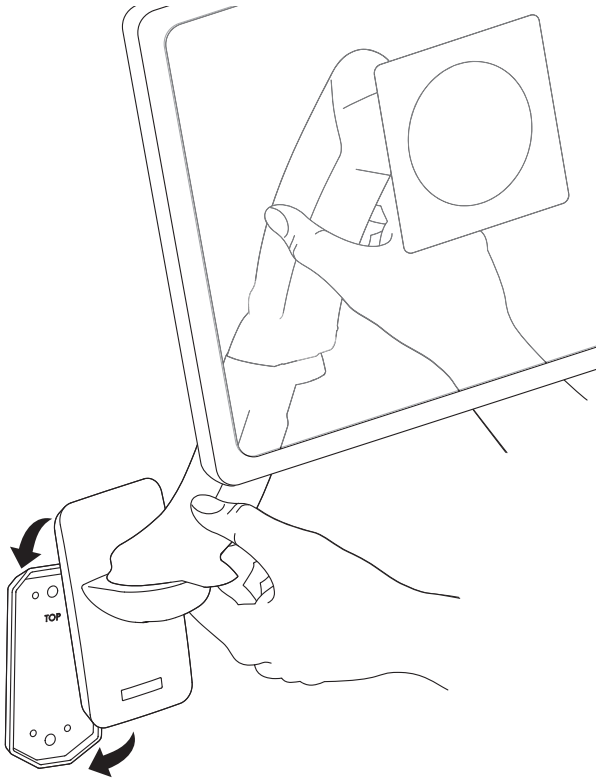

b

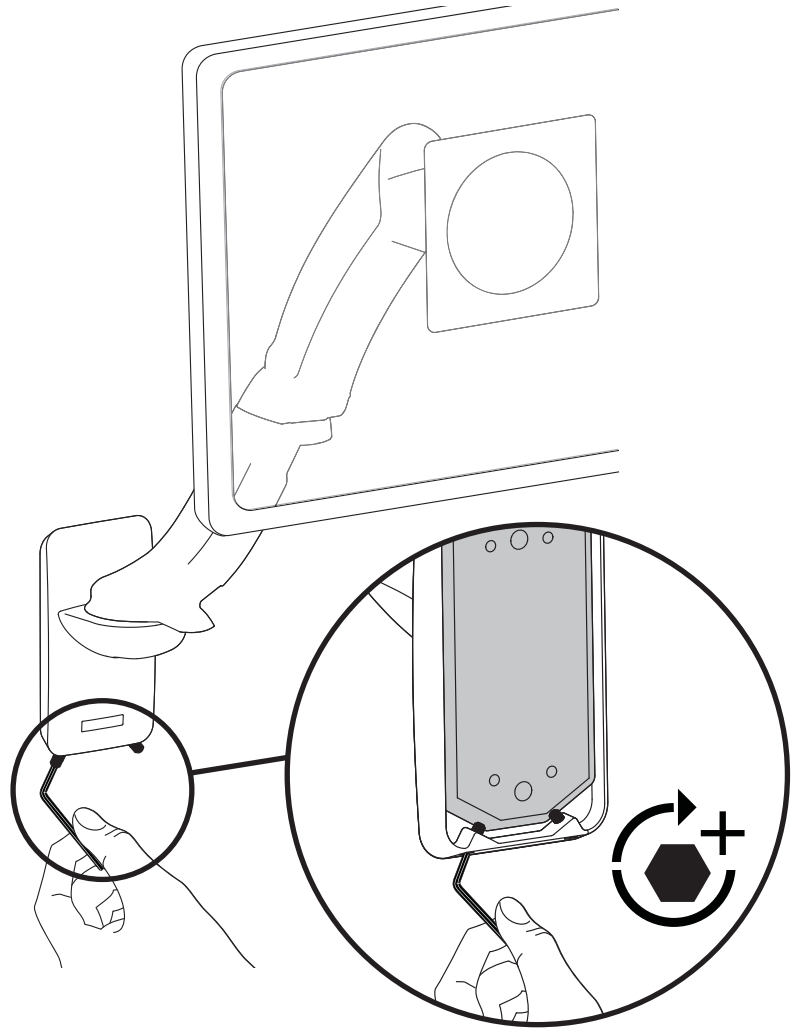

# 7

Cable Routing  
Guía de cableado  
Câblage  
Kabelführung  
ケーブルの配線



NOTE: Leave enough slack in cable to allow full range of motion.



Caution: To avoid the potential to pinch cables it is important to follow the cable routing instructions in this manual. Failure to follow these instructions may result in equipment damage or personal injury.



NOTA: Deje suficiente holgura en los cables para permitir su rango completo de movimiento.



Precaución: Para evitar la posibilidad de que se doblen los cables, es importante seguir las instrucciones de organización de los cables de este manual. En caso de no respetar estas instrucciones, podrían producirse daños en el equipo o lesiones físicas.



REMARQUE : Laissez suffisamment de mou dans le cordon pour permettre au mouvement de haut en bas de se faire sur toute la hauteur.



Attention : Pour éviter de risquer de pincer les câbles, il est important de suivre les instructions d'acheminement des câbles de ce manuel. Le non-respect de cette consigne peut entraîner des dommages matériels et/ou des blessures.



HINWEIS: Lassen Sie für das Kabel ausreichend Spielraum, um eine uneingeschränkte Bewegung zu gewährleisten.



Vorsicht: Damit keine Kabel eingeklemmt werden können, müssen Sie die Anweisungen zur Kabelführung in diesem Handbuch einhalten. Ein Missachten dieser Anweisungen kann zu Geräteschäden oder Verletzungen führen.



注: ケーブルが自由に動くよう、たるませた状態で配線します。



注意: ケーブルの挟まりを防ぐため、必ず本マニュアルのケーブル配線手順に従ってください。この指示に従わないと、機器の損傷や怪我を招く恐れがあります。

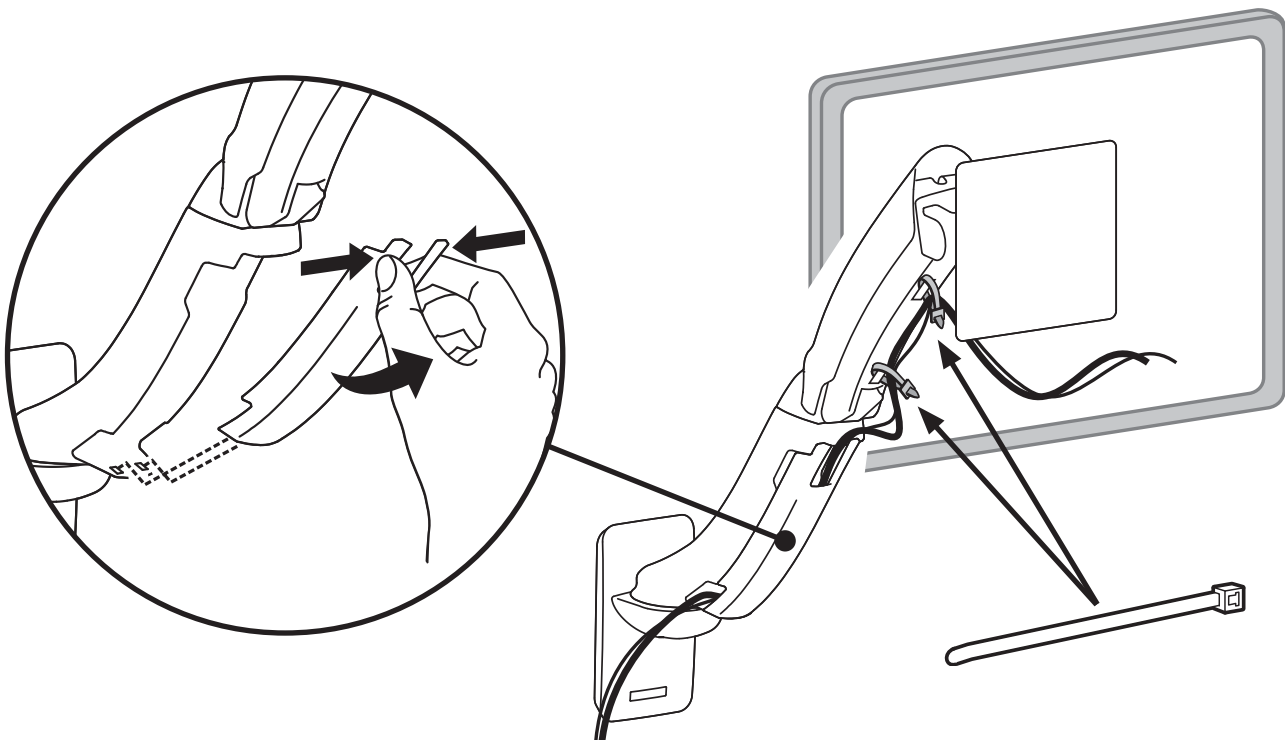

8



Important! You will need to adjust this product after installation is complete. Make sure all your equipment is properly installed on the product before attempting adjustments. This product should move smoothly and easily through the full range of motion and stay where you set it. If movements are too easy or difficult or if product does not stay in desired positions, follow the adjustment instructions to create smooth and easy movements. Depending on your product and the adjustment, it may take many turns to notice a difference. Any time equipment is added or removed from this product, resulting in a change in the weight of the mounted load, you should repeat these adjustment steps to ensure safe and optimum operation.

¡Importante! Tendrá que ajustar este producto una vez que haya terminado la instalación. Asegúrese de que todo su equipo esté instalado correctamente en el producto antes de intentar llevar a cabo algún ajuste. Este producto debe poder moverse de manera fácil y firme dentro de la amplitud de movimiento permitida y mantenerse donde usted lo fije. Si los movimientos son demasiado fáciles o difíciles o si el producto no se mantiene en las posiciones deseadas, siga las instrucciones de ajuste para conseguir movimientos suaves y fáciles. Dependiendo del producto y el ajuste, es posible que deba hacer muchos intentos hasta poder observar la diferencia. Cada vez que añada o retire equipos de este producto y que produzca un cambio en el peso de la carga, debe repetir estos pasos de ajuste para garantizar un funcionamiento seguro y óptimo.

Important ! Vous devez ajuster le produit une fois l'installation terminée. Assurez-vous que l'équipement est correctement installé sur le produit avant de procéder aux ajustements. Ce produit doit pouvoir être déplacé sans difficulté sur toute la plage de mouvement et rester immobilisé à l'endroit où il est réglé. Si le mouvement est trop facile ou trop difficile, ou si le produit ne reste pas dans les positions souhaitées, procédez selon les instructions de réglage pour harmoniser les mouvements. En fonction de votre produit et du réglage, plusieurs tours peuvent s'avérer nécessaire pour remarquer la différence. Chaque fois qu'une pièce d'équipement est ajoutée ou retirée de ce produit, affectant en conséquence le poids de la charge montée, vous devez répéter ces étapes de réglage afin de garantir une utilisation sécurisée et optimale du produit.

Wichtig! Sie müssen dieses Produkt nach dem Zusammenbau entsprechend einstellen. Achten Sie darauf, dass alle Ihre Geräte richtig auf dem Produkt installiert wurden, bevor Sie irgendwelche Einstellungen vorzunehmen versuchen. Dieses Produkt sollte sich in seinem gesamten Bewegungsbereich ruckfrei und ohne Schwierigkeiten bewegen lassen und an der Stelle bleiben, an der es abgestellt wird. Wenn die Bewegungen zu leicht oder nur mit großer Anstrengung durchgeführt werden können oder das Produkt nicht in der vorgesehenen Position bleibt, beachten Sie die Einstellanleitung, um ruckfreie und einfache Bewegungen zu ermöglichen. Je nach Ihrem Produkt und der jeweiligen Einstellung können zahlreiche Manipulationen erforderlich sein, bevor Sie einen Unterschied feststellen. Zur Sicherstellung einer sicheren und optimalen Produktfunktion sollten Sie diese Einstellschritte immer dann durchführen, wenn Geräte hinzugefügt oder entfernt werden, was eine Veränderung der Traglast zur Folge hat.

重要！本製品は取り付け後に調整する必要があります。調整を行う前に、すべての機器が本製品に適切に取り付けられていることを確認してください。本製品は可動範囲内でスムーズかつ簡単に動く必要があり、選定した位置にしっかり固定されなければなりません。製品が簡単に動きすぎる場合、動きがぎこちない場合、あるいは目的の位置に固定されない場合は、説明書に従いスムーズに動くように調整してください。お使いの製品や調整によっては、違いがはっきりするまで何回か回さなければならないこともあります。本製品に機器を追加したり、機器を取り外したことで積載重量が変わった場合は、安全かつ最適な操作を実現するために調節手順を繰り返してください。

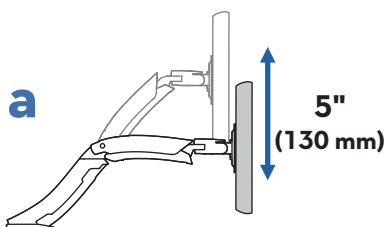

**Lift - Up and down**  
**Elevación (arriba y abajo)**  
**Ajustement en hauteur : bas et haut**  
**Höhenverstellung - rauf und runter**  
**リフト(上下)**

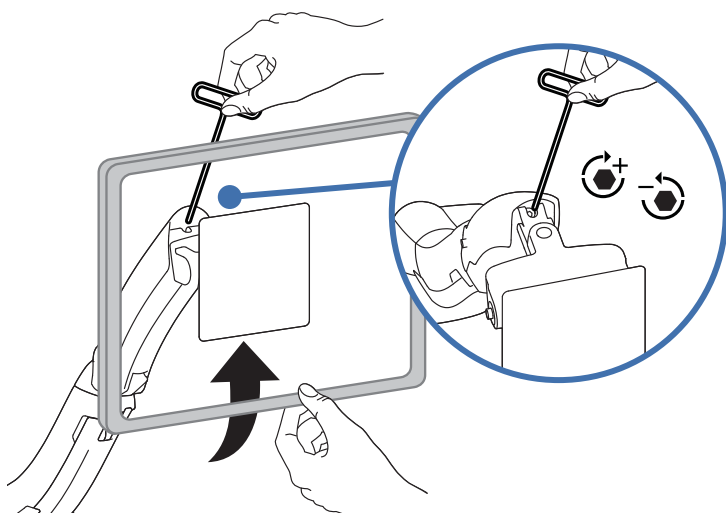

**Increase Lift Strength**  
 If the mounted weight is too heavy or this product does not stay up when raised, then you'll need to increase Lift Strength:

**Aumentar la fuerza de elevación**  
 Si el peso colocado es demasiado o si el producto no se mantiene arriba cuando se eleva, debe aumentar la fuerza de elevación:

**Augmenter la force de levage**  
 Si le poids installé est trop lourd ou si le produit ne reste pas en place une fois soulevé, vous devez augmenter la force de levage :

**Hubkraft erhöhen**  
 Wenn die installierten Geräte zu schwer sind oder das angehobene Produkt nicht oben bleibt, muss die Hubkraft erhöht werden:

リフト強度の増大  
 積載重量が重すぎる場合、または本製品の位置を上げてても下がってくる場合には、リフト強度を高める必要があります。



**Decrease Lift Strength**  
 If the mounted weight is too light or this product does not stay down when lowered, then you'll need to decrease Lift Strength:

**Reducir la fuerza de elevación**  
 Si el peso colocado es muy poco o si el producto no se mantiene abajo cuando se baja, tendrá que disminuir la fuerza de elevación:

**Réduire la force de levage**  
 Si le poids installé est trop faible ou si le produit ne reste pas en place une fois abaissé, vous devez réduire la force de levage :

**Hubkraft senken**  
 Wenn die installierten Geräte zu leicht sind oder das abgesenkte Produkt nicht unten bleibt, muss die Hubkraft reduziert werden:

リフト強度の低減  
 積載重量が軽すぎる場合、または本製品の位置を下げてても上がった場合には、リフト強度を弱める必要があります。

**b** Tilt - Forward and Backward  
 Inclinación (adelante y atrás)  
 Inclinaison : Avant et arrière  
 Neigung - vor und zurück  
 チルト (前後)

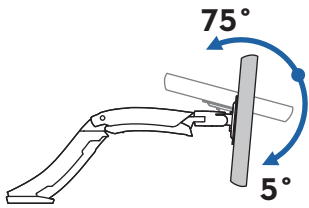

**Increase Lift Strength**  
 If the mounted weight is too heavy or this product does not stay up when raised, then you'll need to increase Lift Strength:

**Aumentar la fuerza de elevación**  
 Si el peso colocado es demasiado o si el producto no se mantiene arriba cuando se eleva, debe aumentar la fuerza de elevación:

**Augmenter la force de levage**  
 Si le poids installé est trop lourd ou si le produit ne reste pas en place une fois soulevé, vous devez augmenter la force de levage :

**Hubkraft erhöhen**  
 Wenn die installierten Geräte zu schwer sind oder das angehobene Produkt nicht oben bleibt, muss die Hubkraft erhöht werden:

**リフト強度の増大**  
 積載重量が重すぎる場合、または本製品の位置を上げてても下がってくる場合には、リフト強度を高める必要があります。



**Decrease Lift Strength**  
 If the mounted weight is too light or this product does not stay down when lowered, then you'll need to decrease Lift Strength:

**Reducir la fuerza de elevación**  
 Si el peso colocado es muy poco o si el producto no se mantiene abajo cuando se baja, tendrá que disminuir la fuerza de elevación:

**Réduire la force de levage**  
 Si le poids installé est trop faible ou si le produit ne reste pas en place une fois abaissé, vous devez réduire la force de levage :

**Hubkraft senken**  
 Wenn die installierten Geräte zu leicht sind oder das abgesenkte Produkt nicht unten bleibt, muss die Hubkraft reduziert werden:

**リフト強度の低減**  
 積載重量が軽すぎる場合、または本製品の位置を下げてても上がってくる場合には、リフト強度を弱める必要があります。

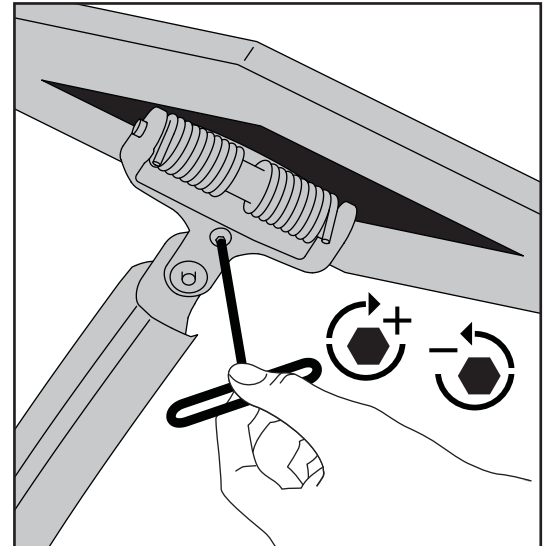
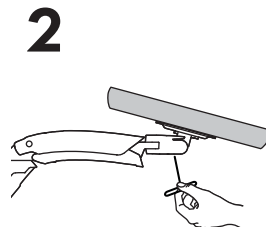
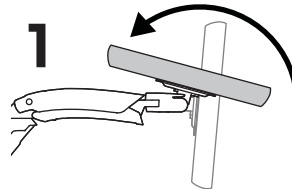

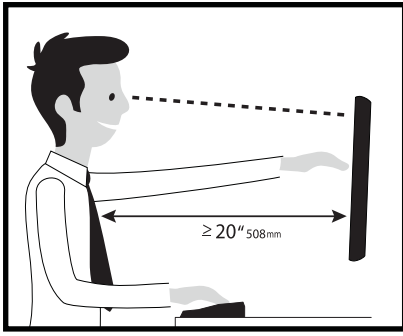

Learn more about ergonomic computer use at: [www.ergotron.com/ergonomics](http://www.ergotron.com/ergonomics)

- EN** For the latest User Installation Guide please visit: [www.ergotron.com](http://www.ergotron.com)  
For Warranty visit: [www.ergotron.com/warranty](http://www.ergotron.com/warranty)  
For Service visit: [www.ergotron.com](http://www.ergotron.com)  
For local customer care phone numbers visit: <http://contact.ergotron.com>
- ES** Para acceder a la última versión de la Guía de instalación para el usuario, ingrese a [www.ergotron.com](http://www.ergotron.com)  
Para Garantía, visite: [www.ergotron.com/warranty](http://www.ergotron.com/warranty)  
Para servicio, visite: [www.ergotron.com](http://www.ergotron.com)  
Para conocer los números telefónicos locales de atención al cliente, visite: <http://contact.ergotron.com>
- FR** Pour la dernière version du Guide d'installation de l'utilisateur, visitez : [www.ergotron.com](http://www.ergotron.com).  
Pour la garantie, visitez: [www.ergotron.com/warranty](http://www.ergotron.com/warranty)  
Pour le service client, visitez: [www.ergotron.com](http://www.ergotron.com)  
Pour les numéros de téléphone du service client local, visitez : <http://contact.ergotron.com>
- DE** Die aktuellste Anleitung für die Montage durch den Benutzer finden Sie hier: [www.ergotron.com](http://www.ergotron.com)  
Für Garantie Besuch: [www.ergotron.com/warranty](http://www.ergotron.com/warranty)  
Für Servicebesuch: [www.ergotron.com](http://www.ergotron.com)  
Örtliche Telefonnummern für den Kundendienst finden Sie hier: <http://contact.ergotron.com>
- JA** 最新のユーザー インストール ガイドは、[www.ergotron.com](http://www.ergotron.com) でご確認ください。  
保証書をご覧ください: [www.ergotron.com/warranty](http://www.ergotron.com/warranty)  
サービスをご覧ください: [www.ergotron.com](http://www.ergotron.com)  
最寄りのカスタマー ケアの電話番号については、こちらをご覧ください: <http://contact.ergotron.com>

# ergotron®

[www.ergotron.com](http://www.ergotron.com) | USA: 1-800-888-8458 | Europe: +31 (0)33-45 45 600 | China: 400-120-3051 | Japan: [japansupport@ergotron.com](mailto:japansupport@ergotron.com)

© 2016 Ergotron, Inc. All rights reserved.

While Ergotron, Inc. makes every effort to provide accurate and complete information on the installation and use of its products, it will not be held liable for any editorial errors or omissions (including those made in the process of translation from English to another language), or for incidental, special or consequential damages of any nature resulting from furnishing this instruction and performance of equipment in connection with this instruction. Ergotron, Inc. reserves the right to make changes in the product design and/or product documentation without notification to its users. For the most current product information, or to know if this document is available in languages other than those herein, please contact Ergotron. No part of this publication may be reproduced, stored in a retrieval system, or transmitted in any form or by any means, electronic, mechanical, photocopying, recording or otherwise without the prior written consent of Ergotron, Inc., 1181 Trapp Road, Eagan, Minnesota, 55121, USA Patents Pending and Patented U.S. & Foreign. Ergotron is a registered trademark of Ergotron, Inc.

# ergotron®

---

## MX Wallmount LCD Arm

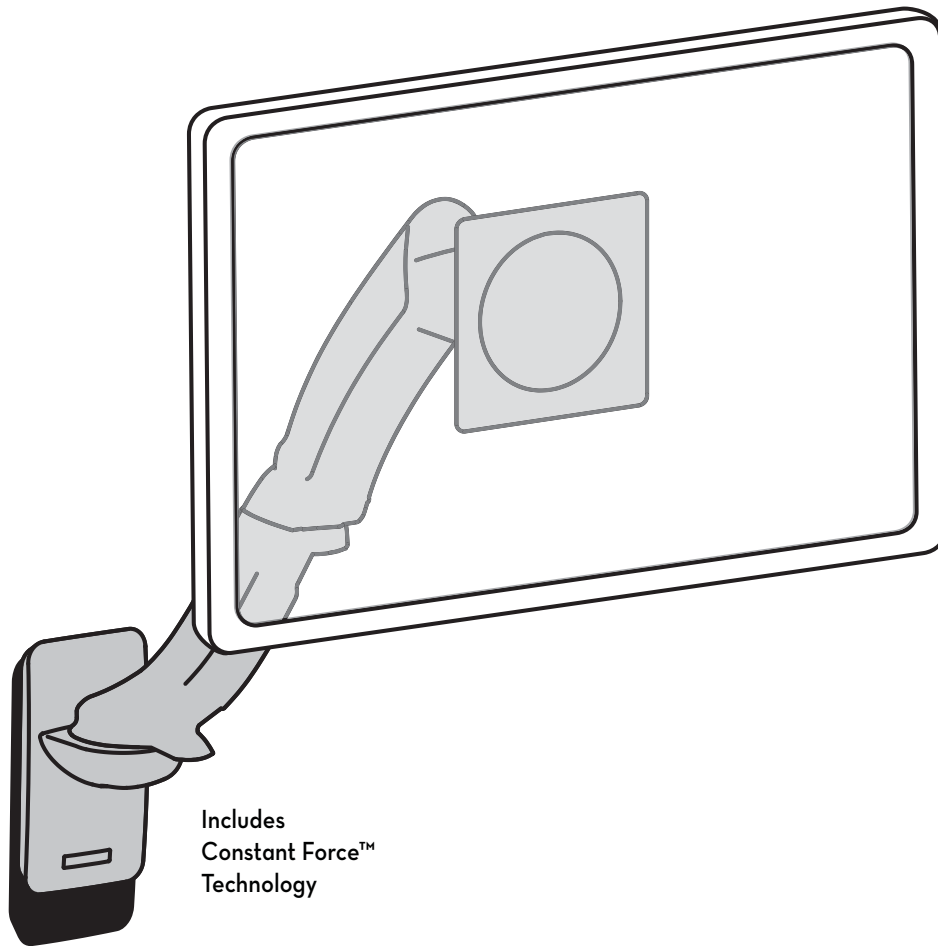

**ZH** 用户指南

**NL** Gebruikersgids

**IT** Guida per l'utente

**TR** Kullanıcı Kılavuzu



[www.ergotron.com](http://www.ergotron.com): English, Español, Français, Deutsch, Nederlands, Italiano, Türkçe, 日本語, 汉语

[www.ergotron.com](http://www.ergotron.com) | USA: 1-800-888-8458 | Europe: +31 (0)33-45 45 600 | China: 400-120-3051 | Japan: [japansupport@ergotron.com](mailto:japansupport@ergotron.com)



## Overzicht symbolen voor gevaren

Deze symbolen waarschuwen gebruikers voor een veiligheidsomstandigheid waaraan aandacht besteed moet worden. Alle gebruikers moeten het belang van de volgende Veiligheidsgevaaren kunnen herkennen en begrijpen als zij daarmee geconfronteerd worden op het product of in de documentatie. Kinderen die de Veiligheidswaarschuwingen niet kunnen herkennen en niet op de juiste wijze daarop kunnen reageren mogen dit product niet gebruiken zonder toezicht van volwassenen!

## Esame dei simboli di pericolo





Questi simboli avvisano gli utenti di una condizione di sicurezza che richiede attenzione. Tutti gli utenti devono essere in grado di riconoscere e comprendere il significato dei seguenti Pericoli per la sicurezza, se compaiono sul prodotto o all'interno della documentazione. I bambini non in grado di riconoscere e reagire nel modo appropriato ai Pericoli per la sicurezza non devono utilizzare questo prodotto senza la sorveglianza di un adulto!

## Tehlike Simgelerinin Gözden Geçirilmesi

Bu simgeler dikkat gerektiren güvenlik durumları hakkında kullanıcıya uyarı vermektedir. Tüm kullanıcılar ürün üzerinde veya dokümanlarda karşılaşılabilecek şekilde aşağıda belirtilen Güvenlik Tehlikelerinin önemini bilmeli ve anlamalıdır. Güvenlik Uyarılarını doğru bir şekilde anlayamayan ve bunlara cevap veremeyen çocuklar erişkin gözetimi olmadan bu ürünü kullanmamalıdır!

## 危险标志回顾

这些标志提醒用户需要注意的安全状况。如果在产品上或者在文件中遇到以下标志，所有用户应能够识别和理解这些安全标志的含义。无法识别并对安全警报作出相应反应的儿童必须在成年人的监督下使用本产品！

Symbool Simbolo Simge 标志	Woordsignaal Indicazione di avvertenza İşaret Sözcüğü 信号文字	Gevarenniveau Livello di pericolo Tehlike Seviyesi 危险等级
	LET OP NOTA NOT 注	EEN OPMERKING geeft aan dat er belangrijke informatie is die u helpt dit product beter te gebruiken. Le NOTE contengono informazioni importanti per un uso migliore del prodotto. Bu ürünü daha iyi kullanmanızı sağlayan önemli bilgilerin yer aldığı NOT. “注”表示可以帮助您更好地使用本产品的重要信息。
	VOORZICHTIG ATTENZIONE DİKKAT 小心	VOORZICHTIG geeft aan dat er mogelijke schade kan ontstaan aan de hardware of verlies van data en vertelt u hoe het probleem te vermijden. Il simbolo ATTENZIONE segnala un potenziale danno all'hardware o la perdita di dati e spiega come evitare il problema. DİKKAT ifadesi donanımdaki olası hasarı veya veri kaybını göstermekte ve sorunu nasıl önleyeceğinizi açıklamaktadır. “小心”表示可能损坏硬件或丢失数据，告诉您如何避免。
	WAARSCHUWING AVVERTENZA UYARI 小心	Een WAARSCHUWING geeft aan dat er een kans is op beschadiging van apparatuur, verwonding van een persoon, of een dodelijk ongeluk. Le AVVERTENZE indicano la possibilità di danni agli oggetti, infortuni o morte. UYARI ifadesi mal hasarı, kişisel yaralanma veya ölüm riskini ifade etmektedir. “警告”表示潜在的财产损失、人员伤亡。
	ELEKTRISCH ELETTRICO ELEKTRİK 电气	Elektrisch geeft een kans op een elektrisch gevaar aan, dat - als het niet vermeden wordt - verwonding van een persoon, brand en/of overlijden tot gevolg kan hebben. L'indicazione Elettrico indica un pericolo elettrico incombente che, se non evitato, potrebbe causare infortuni, incendi e/o morte. Elektrik ifadesi, önlenmemesi halinde yaralanma, yangın ve/veya ölümlü sonuçlanabilecek olası elektrik tehlikesini ifade etmektedir. “电气”表示可能的电气危险，如果不能避免，可能会导致人员受伤、火灾和/或死亡。



**Belangrijk!** U moet dit product bijstellen nadat de installatie voltooid is. Overtuig u ervan dat al uw apparatuur op de juiste wijze geïnstalleerd is op het product voordat u probeert bijstellingen uit te voeren. Dit product moet soepel en makkelijk bewegen door alle bewegingen en blijven staan waar u het zet. Als het te makkelijk of moeilijk beweegt of als het product niet in de gewenste posities blijft staan, volg dan de instructies voor het bijstellen om te zorgen voor soepele en makkelijke bewegingen. Afhankelijk van uw product en de bijstelling moet u mogelijk veel aan de schroeven en knoppen draaien om een verschil te merken. Elke keer als apparatuur toegevoegd of verwijderd wordt van dit product met als resultaat een verandering in het gewicht van de gemonteerde belasting, moet u deze stappen voor bijstelling opnieuw doorlopen om te zorgen voor een veilige en beste werking.

**Importante!** Al termine dell'installazione, sarà necessario regolare questo prodotto. Verificare che tutte le apparecchiature siano correttamente installate sul prodotto, prima di cercare di eseguire le regolazioni. Questo prodotto deve spostarsi in modo uniforme e scorrevole attraverso l'intero raggio di movimento, nonché restare fermo nel punto in cui viene collocato. Se gli spostamenti appaiono troppo agevoli o troppo difficoltosi, oppure se il prodotto non resta nelle posizioni previste, attenersi alle istruzioni sulla regolazione per ottenere spostamenti uniformi e scorrevoli. In base al prodotto e alla regolazione, è possibile che siano necessari molti giri per notare la differenza. Ogni volta che si aggiungono o tolgono apparecchiature dal prodotto, determinando una modifica nel peso del carico montato, occorre ripetere questi passaggi di regolazione, per garantire un funzionamento sicuro e ottimale.

**Önemli!** Montaj tamamlandıktan sonra bu ürünü ayarlamamız gerekecektir. Ayarlamalar yapmadan önce tüm donanımınızın ürün üzerine düzgün şekilde monte edildiğinden emin olun. Bu ürün tüm hareket alanı boyunca düzgünce ve kolayca hareket etmeli ve ayarladığınız yerde kalmalıdır. Eğer hareketler çok kolay veya çok zorsa ya da ürün istenen konumlarda durmuyorsa, düzgün ve kolay hareketler oluşturmak için ayar talimatlarını izleyin. Ürünüze ve ayara bağlı olarak bir farkın tespiti için birçok dönüş gerekebilir. Monte edilen yükün ağırlığında bir değişikliğe yol açacak bir donanımı bu ürün üzerine eklediğiniz veya çıkardığınız zaman güvenli ve en uygun çalışmayı sağlamak üzere bu ayar adımlarını tekrarlamalısınız.

**重要说明!** 本产品安装完成后需要调节。在尝试进行调节之前，确保所有设备都正确安装在产品上。本产品应能在整个动作范围内灵活自如地移动，并能固定在所设定的位置。如果移动过于容易或过于困难，或者产品不能固定在想要的位置上，请按照调节说明操作，使动作灵活自如。根据您所用产品及调节方式，可能需要旋转几圈后才能注意到差别。每次添加或者从本产品上拆除设备时，都会使安装负荷重量发生变化，您应该重复调节步骤，确保运行状态安全、最佳。



**Waarschuwing:** Omdat materiaal voor de oppervlakken van bevestigingsstukken nogal verschillend kan zijn, is het van het grootste belang dat u ervoor zorgt dat het oppervlak van het bevestigingsstuk sterk genoeg is om daarop gezette producten en apparatuur te behandelen.

**Avvertenza:** poiché i materiali delle superfici di montaggio possono variare enormemente, è essenziale accertarsi che la superficie di montaggio sia abbastanza forte da poter sostenere il prodotto e l'apparecchiatura montati.

**Uyarı:** Montaj yüzeyi malzemeleri büyük ölçüde çeşitlilik gösterebileceğinden, montaj yüzeyinin monte edilen ürünü ve donanımı taşıyabilecek kadar güçlü olduğundan emin olmanız şarttır.

**警告:** 由于安装表面材质差异很大，必须确保安装表面足以支撑所安装的产品和设备。



**Voorzichtig:**

Om te voorkomen dat de snoeren mogelijk beklemd raken, dient u de instructies voor het leiden van de snoeren in dit handboek te volgen. Nalaten deze instructies te volgen kan de apparatuur beschadigen of persoonlijk letsel veroorzaken.

**Attenzione:**

Per evitare la possibilità di schiacciare i cavi, è importante seguire le istruzioni di instradamento dei cavi riportate nel presente manuale. La mancata osservanza delle presenti istruzioni può causare danni alle cose o infortuni personali.

**Dikkat:**

Kablolarda sıkışma olasılığını önlemek için bu el kitabındaki kablo yönlendirme talimatlarına uymak önemlidir. Bu talimatlara uyulmaması donanımda hasar ve/veya kişisel yaralanmayla sonuçlanabilir!

**小心:**

为了避免夹住线缆，请务必遵守本手册中的布线说明。不遵守本警告指示可能导致设备损坏或人身伤害。

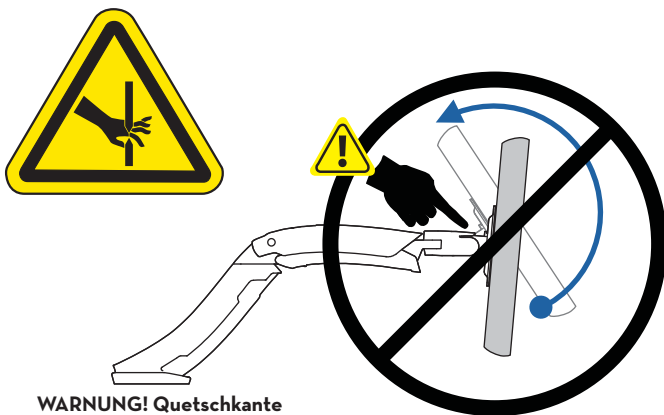

**WARNUNG! Quetschkante**

**AVVERTENZA! Punto di possibile schiacciamento**

**UYARI! KISTIRMA NOKTASI**

**警告！小心被夹**



**NL** WAARSCHUWING! Gevaar door opgeslagen energie: het hefmechanisme van het werkoppervlak staat onder spanning en verplaatst zich zelfstandig snel omhoog wanneer de bevestigde apparatuur wordt verwijderd. Verwijder apparatuur daarom ALLEEN nadat de arm in de hoogste stand is gezet! Als u deze instructie niet opvolgt, kan dit tot ernstig persoonlijk letsel en/of beschadiging van de apparatuur leiden!

**IT** AVVERTENZA! Rischio da energia immagazzinata: il meccanismo del braccio è sotto tensione e si muove rapidamente da sé non appena si toglie l'apparecchiatura a cui è collegato. Per questo motivo, NON rimuovere l'apparecchio a meno che il braccio non sia stata portato sulla posizione più alta. La mancata osservanza di questa precauzione può causare infortuni gravi e/o danni all'apparecchiatura.

**TR** UYARI:  
Depolanmış Enerji Tehlikesi: Kol mekanizması gerilmiş durumdadır ve takılmış olan donanım çıkarıldığı an kendi kendine hızla yukarı doğru hareket edecektir. Bu nedenle kol en yüksek konuma taşınmadığı sürece donanımı ÇIKARMAYIN! Bu talimata uyulmaması ciddi kişisel yaralanma ve/veya donanım hasarıyla sonuçlanabilir!

**ZH** 警告！储能危险：支臂机构处于受力状态，在拆除所安装的设备后会自行快速上升。因此，在将支臂移到最高位置之前，不要拆除设备！不遵守本规定可能导致严重的人身伤害和/或设备损坏！

Kenmerken en specificaties  
Caratteristiche e dati tecnici  
Nitelikler ve Teknik Özellikler  
特点和规格



14 - 30 lbs. (6.35 - 13.61 kg)

VOORZICHTIG: OVERSCHRIJD DE MAXIMUM OPGEGEVEN GEWICHTSCAPACITEIT NIET. DIT KAN LEIDEN TOT ERNSTIGE VERWONDINGEN OF BESCHADIGING VAN BEZIT.

ATTENZIONE: NON SUPERARE LA CAPACITÀ DI CARICO MASSIMA INDICATA. POTREBBERO VERIFICARSI INFORTUNI O DANNI AGLI OGGETTI!

DİKKAT: BELİRTİLEN EN YÜKSEK AĞIRLIK SINIRINI AŞMAYIN. CİDDİ YARALANMA VEYA MAL HASARI OLUŞABİLİR!

注意：请勿超过所列的最大可承重量。否则可能导致重伤或设备损坏！

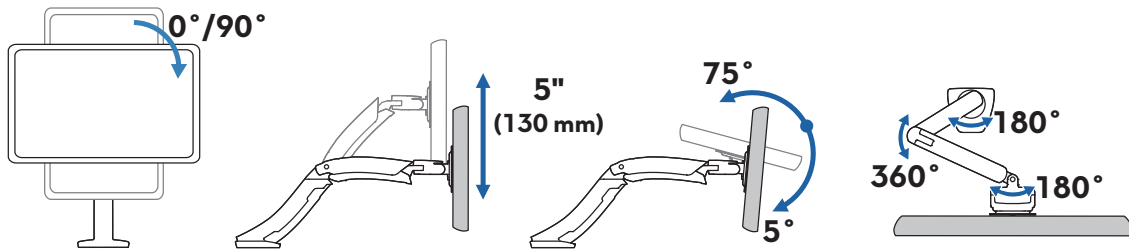
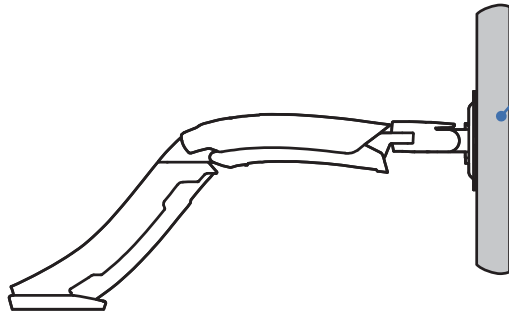











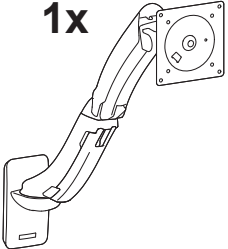



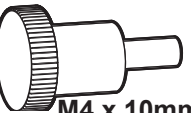

Onderdelen

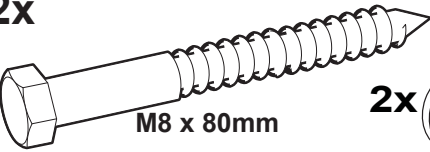
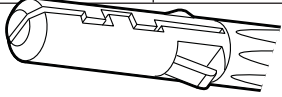
Componenti

Bileşenler

部件

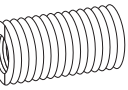

	A	B	C	D	E
1	1x 	1x 	1x  M3 x 6mm	1x  4mm	2x  Sterile Alcohol Prep
2	4x  M4 x 10mm	4x  M4 x 10mm	4x  M4 x 12mm	4x  M5 x 7mm	4x  M5 x 12mm
3	2x  M8 x 80mm		2x 	1x  1/8"	
4	2x  8mm		4x 	4x  10-24 x 3/8"	
5	4x 	4x  M6 x 12mm	4x  M8M5 Converter Convertitore M8M5 M8M5 Dönüştürücü M8M5 转接件	4x  M5 x 20mm	

Benodigde gereedschappen  
 Utensili necessari  
 Gerekti Aletler  
 需要的工具

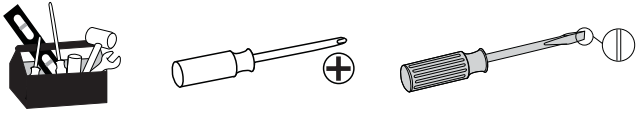

Beton  
 Cemento  
 Beton  
 水泥质

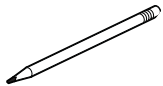
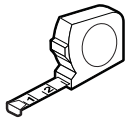
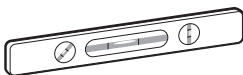
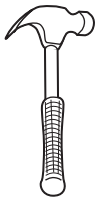
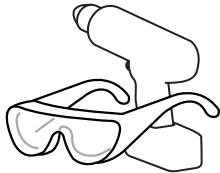
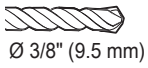
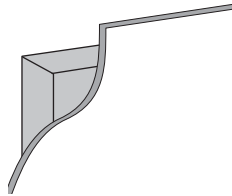

Massief Houten Pilaren  
 Due montanti in legno massiccio  
 Ahşap  
 木质

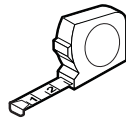
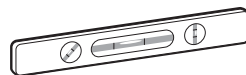
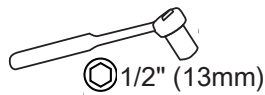
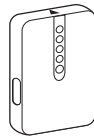
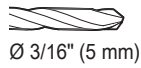
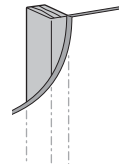

# 1 Opstellingshoogte voor een ergonomisch werkstation

Deze opstellingshoogte wordt aanbevolen voor een ergonomische werkplek geschikt voor gebruikers die 5'4"- 5'9" (162.5-175cm) lang zij als deze opstelling gebruikt wordt om staande te werken en gebruikers die 5'3"-5" (160-180cm) zijn en die zitten.

Als de lengte van de gebruikers anders is, moet u de opstelling aanpassen aan de lengte van de gebruiker. (Verander de opstelhoogte met 2,5 cm voor elke 2,5 cm verschil van de gebruiker).

## Altezza di montaggio per postazione di lavoro ergonomica

Questa altezza di montaggio è raccomandata per una postazione di lavoro ergonomica idonea a utenti la cui altezza è compresa tra 5'4"- 5'9" (162-175cm), quando è approntata per la posizione eretta, mentre accoglie utenti la cui altezza è compresa tra 5'3"-5'11" (160-180cm), quando è approntata per la posizione seduta.

Se gli utenti sono di altezza diversa rispetto agli intervalli suddetti, è necessario modificare l'altezza di montaggio per adattarla a tali persone. (Modificare l'altezza di montaggio di un pollice per ogni pollice di differenza nell'altezza degli utenti).

## Ergonomik İş İstasyonu için Montaj Yüksekliği

Bu montaj yüksekliği, ayakta duruş için kullanıcı yüksekliği olan 5'4"-5'9" (162,5-175cm) ve oturuş için kullanıcı yüksekliği olan 5'3"-5'11" (160-180cm) yüksekliklerine sahip bir ergonomik iş istasyonu elde etmek için bir tavsiyedir.

Kullanıcı yüksekliklerinin yukarıda belirtilen değerden farklı olması halinde montaj yüksekliğinin kullanıcı yüksekliklerine göre değiştirilmesi gerekmektedir. (Kullanıcı yüksekliğindeki her bir inçlik değişiklik için montaj yüksekliğini de bir inç değiştirin).

## 人体工程学工作站的安装高度

这个安装高度是适应站姿高度为 5'4"- 5'9" (162.5-175cm) 和坐姿高度为 5'3"-5'11" (160-180cm) 的用户的人体工程学工作站的推荐安装高度。如果用户身高在此范围以外，您应更改安装高度以适应用户身高。（用户身高每相差一英寸则安装高度更改一英寸）。

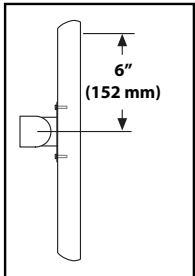

Bij de bevestigingshoogte wordt aangenomen dat er 152 mm ruimte is tussen het midden van de gaten voor het bevestigen van uw monitor en de bovenkant van het scherm. Als uw ruimte kleiner is, moet u de opstellingshoogte overeenkomstig vergroten, als uw ruimte groter is, moet u uw opstellingshoogte overeenkomstig verkleinen.

L'altezza di montaggio presuppone la presenza di una distanza di 6" (152 mm) tra il centro dei fori di montaggio del monitor e la parte superiore dello schermo. Se la distanza risulta minore, occorre aumentare di conseguenza l'altezza di montaggio; se la distanza è maggiore, occorre ridurre di conseguenza l'altezza di montaggio.

Montaj yüksekliği, monitörünüzün montaj deliklerinin orta noktası ile ekranın tepe noktası arasındaki mesafenin 6" (152 mm) olduğunu varsaymaktadır. Mesafenin daha küçük olması halinde montaj yüksekliğinin artırılması gerekirken mesafenin daha büyük olması halinde ise montaj yüksekliğinin azaltılması gerekmektedir.

安装高度假设您的显示器安装孔中心与屏幕顶部之间的距离为 6" (152 mm)。如果您的距离更小，您应相应增加安装高度，如果您的距离更大，您应相应降低您的安装高度。

## Opstellingshoogte voor een ergonomisch werkstation

Altezza di montaggio per postazione di lavoro ergonomica

Ergonomik İş İstasyonu için Montaj Yüksekliği

人体工程学工作站的安装高度

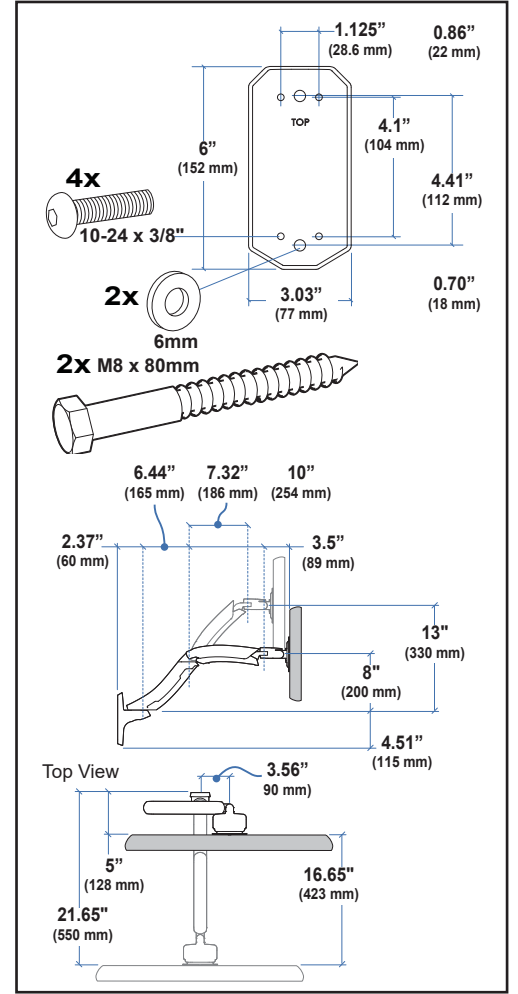
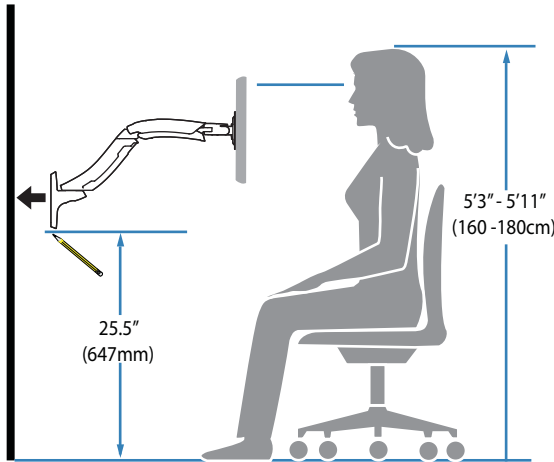
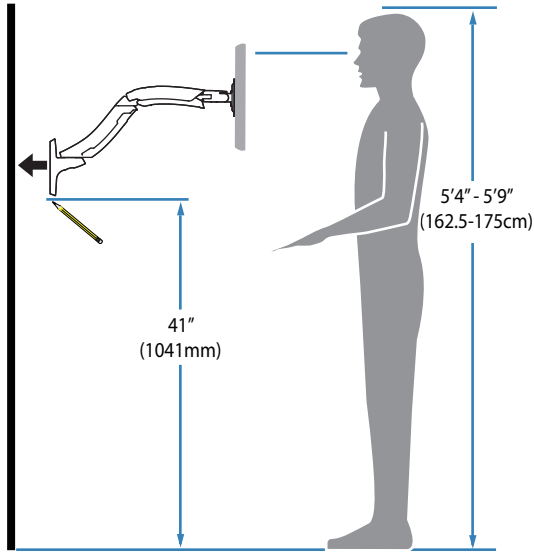

### Bepaal de plaats van de bevestiging:

Van voren gezien, met de arm teruggeduwd tegen de muur.

### Stabilire l'ubicazione di montaggio:

Vista frontale con braccio spinto contro la parete.

### Montaj konumunu belirleyin:

Kol duvara karşı geri itilirken önden görünüş.

### 确定安装位置:

将支臂向后推靠墙的正视图。

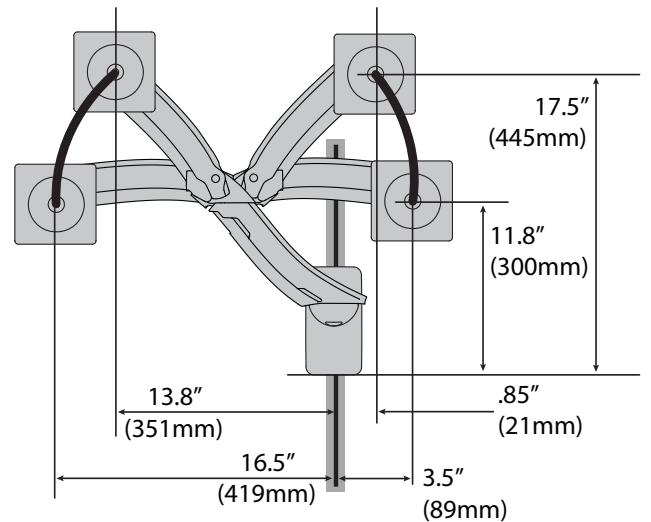



# 2

**Kies de montagemethode. Ergotron-product. Muurrail en -beugel Apart leverbaar**  
**Scegliere il metodo di montaggio. Prodotto Ergotron. Wall Track e staffa Venduta separatamente**  
**Montaj Yöntemini Seçin. Ergotron ürünü. NOT: Duvar Rayı ve Braketler, ayrı satılır.**  
**选取安装方法. Ergotron 产品. 墙轨和托架单独出售。**

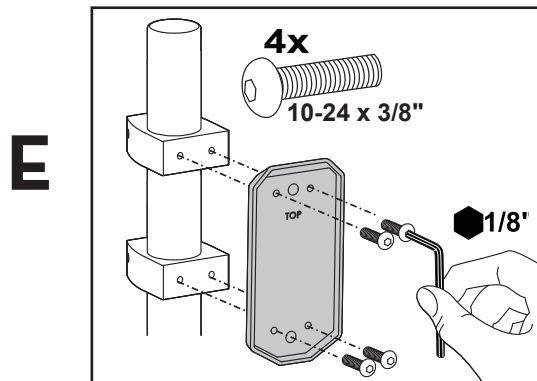
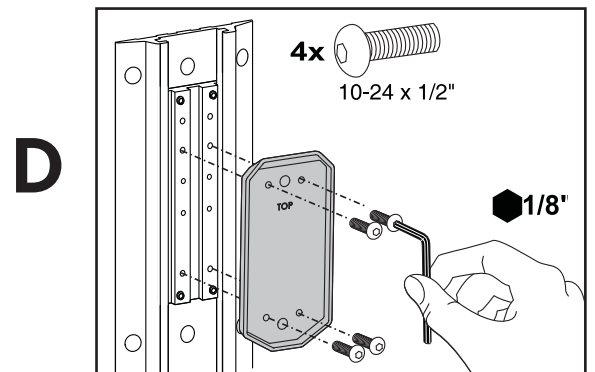
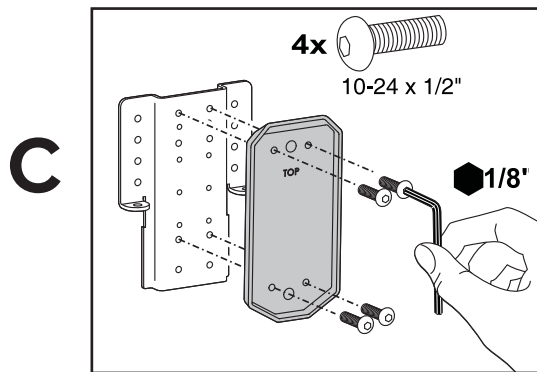
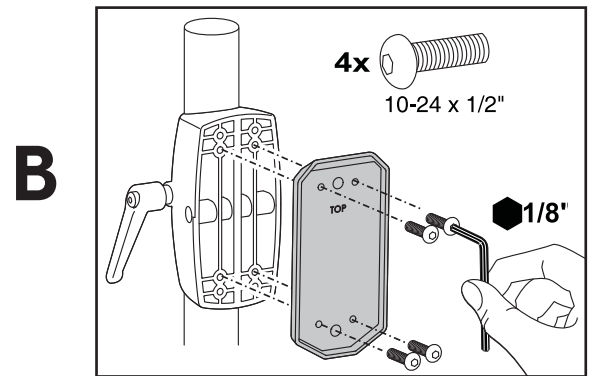
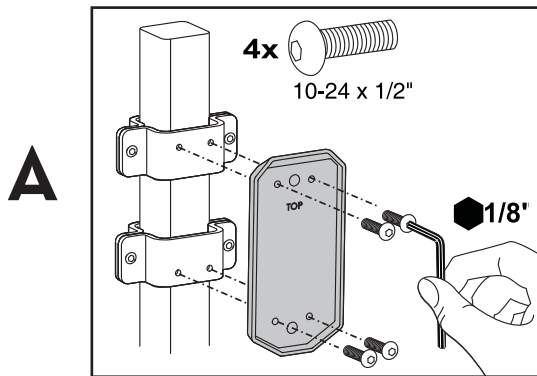

**LET OP:** bij bevestiging aan paalklemmen, gebruik 10-24 x 3/8" schroeven. Gebruik geen 10-24 x 1/2" schroeven!

**Attenzione:** Fissando ai morsetti dell'asta, utilizzare viti da 10-24 x 3/8". Non utilizzare viti da 10-24 x 1/2"!

**Direk Kelepçelerine montaj yaparken direk braketlerine dahil olan 10-24 x 3/8" vidalarını kullanın, 10-24 x 1/2" vidalarını KULLANMAYIN**

**安装到杆夹时，采用10-24 x 3/8"螺丝，不要使用10-24 x 1/2"螺丝**

**F**  
**Beton**  
**Cemento**  
**Beton**  
**水泥质**

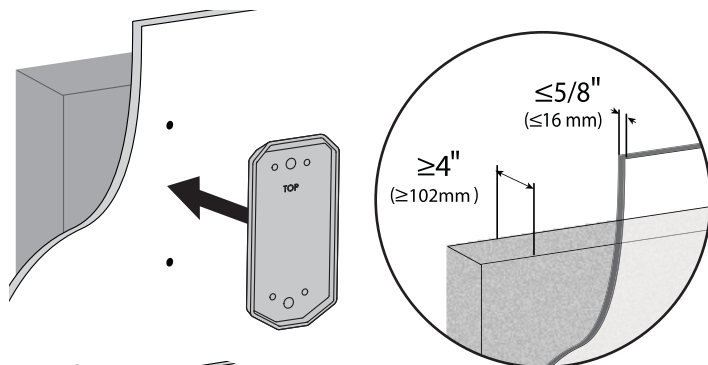

**G**  
**Massief Houten Pilaren**  
**Due montanti in legno massiccio**  
**Ahşap**  
**木质**

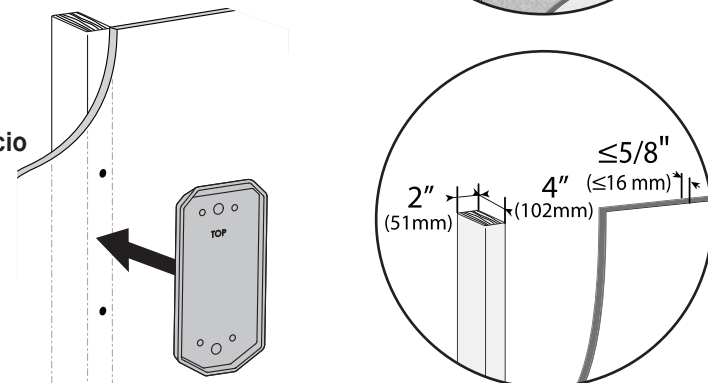

# 2 Beton Cemento Beton 水泥质

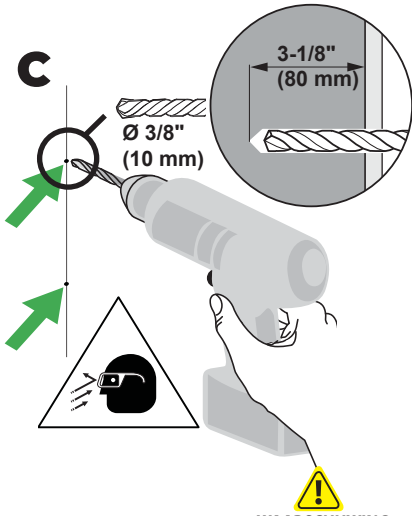
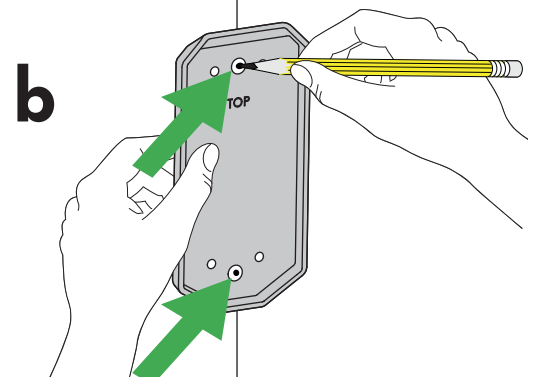
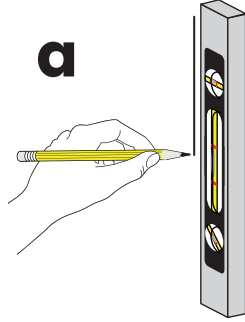
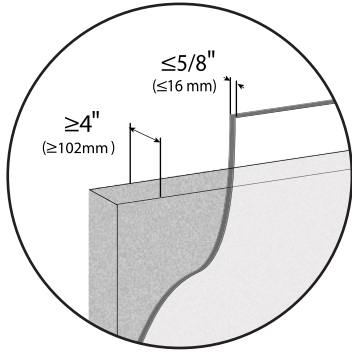

## WAARSCHUWING:

De bevestigingsgaten moeten tenminste 80 mm diep zijn en mogen alleen in massief metselwerk of beton worden geboord, niet in de voegen of in de wandafwerking. Verander de plaats van de bevestigingsgaten wanneer u merkt dat u niet in massief beton boort, totdat alle vier de pluggen volledig in massief beton of metselwerk kunnen worden verankerd.

## ATTENZIONE:

I fori di montaggio devono avere una profondità minima di 80mm e devono essere ricavati nel cemento solido, non calce o materiale di rivestimento. Se incontrate materiale diverso dal cemento, riposizionate i fori di montaggio in modo che tutt'e quattro le viti di montaggio siano inserite nel cemento!

## UYARI:

Montaj delikleri en az 3-1/8" (80mm) derinlikte olmalı ve harç veya kaplama malzemesi yerine sert betona yerleştirilmelidir. Sert olmayan beton bir alanda delme işlemi yapmanız halinde her iki tespit noktası sert betona tamamen yerleştirilinceye kadar montaj deliklerini yeniden konumlandırın!

## 警告:

安装孔的深度至少 3-1/8" (80mm) 并且必须位于硬水泥墙面，而不是灰泥或覆盖材料。如果钻孔碰到不牢固的水泥区，要重新找安装孔，直到锚控能够完全嵌入硬水泥中！

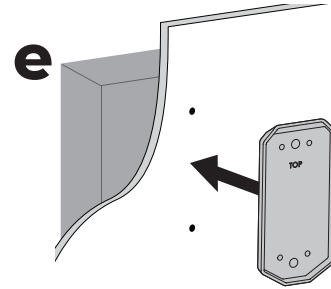
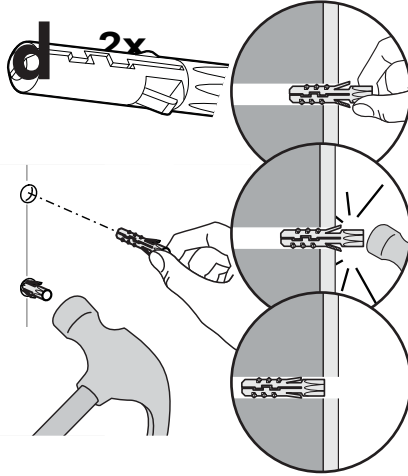

## WAARSCHUWING:

Pluggen die niet volledig in het beton zijn verankerd zullen de op te hangen apparatuur niet kunnen dragen, dit zal leiden tot een onveilige en onstabiele situatie wat lichamelijk letsel en schade aan de muur en het beeldscherm kan veroorzaken.

## ATTENZIONE:

Tasselli che non facciano presa nel cemento non saranno in grado di reggere il carico, con conseguente instabilità e mancanza di sicurezza, che possono condurre a danni alle persone ed alle cose.

## UYARI:

Tespit noktalarının sert betona tamamen yerleştirilmemesi halinde uygulanan yük desteklenmeyecek ve bu durumda oluşan dengesiz ve güvensiz şartlar sebebiyle yaralanma ve/veya mal hasarı meydana gelebilecektir. Kendi özel durumunuzla ilgili bu adım hakkında bilgi almak için bir inşaat uzmanına başvurun.

## 警告:

没有完全嵌入的锚控无法支撑重量，结果造成不稳定、不安全的情况，这会导致人员及或财产伤害。如果您对具体应用还存有疑惑，请咨询建筑专业人士。

## 2 Massief Houten Pilaren Due montanti in legno massiccio Ahşap 木质

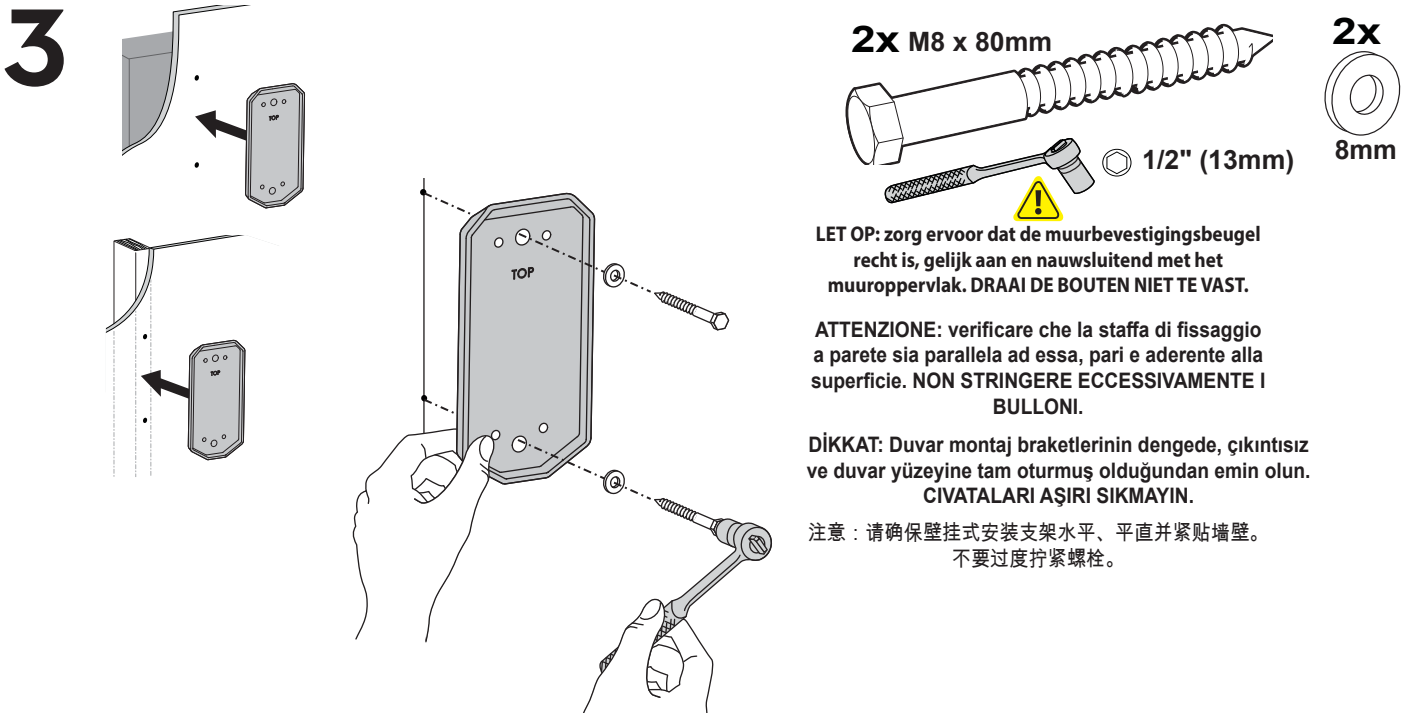
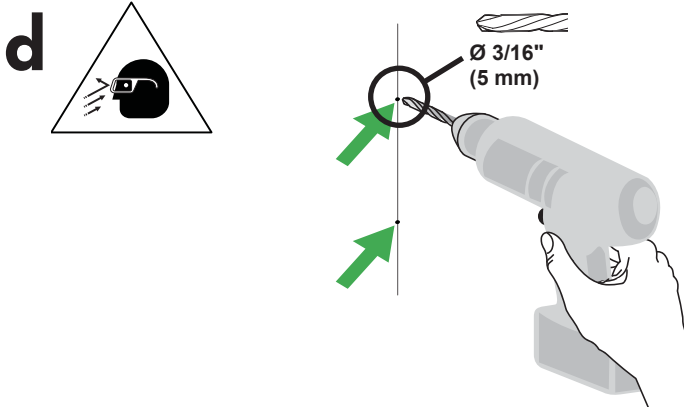
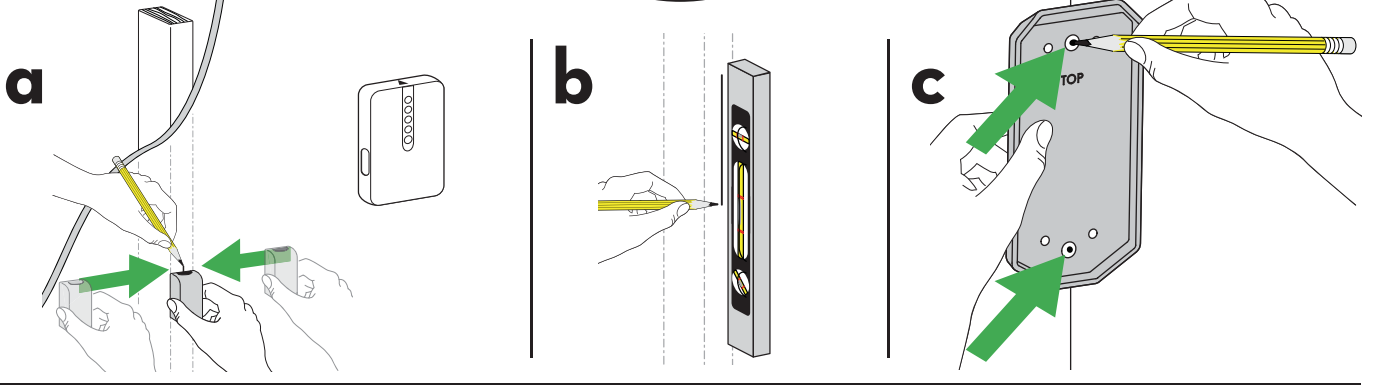
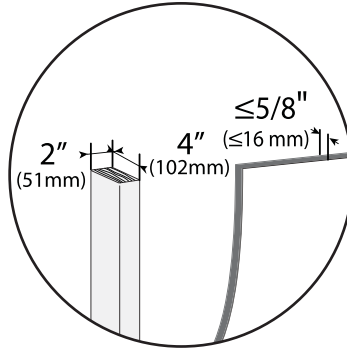

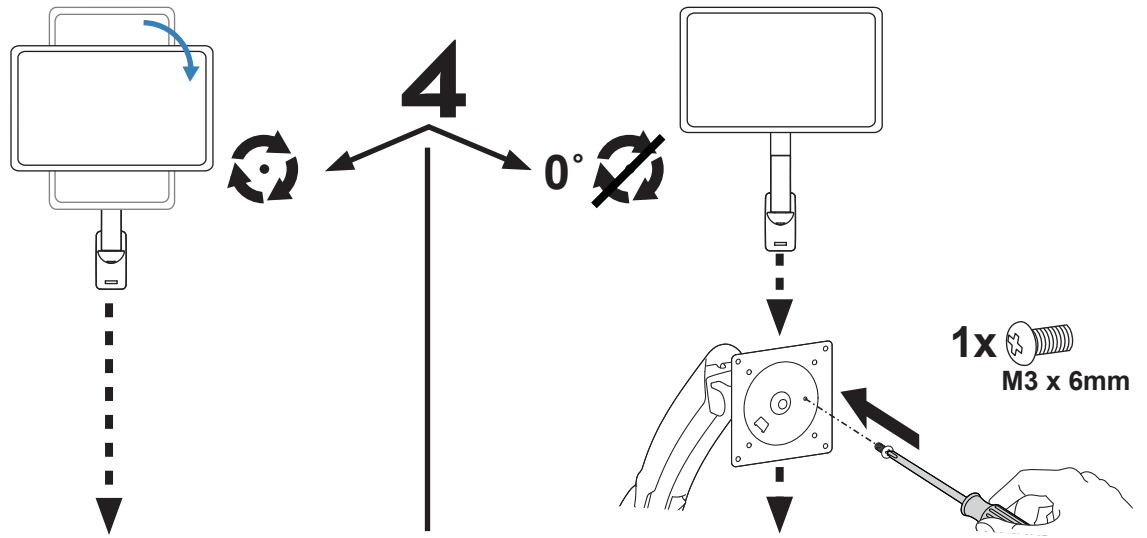

**5**

Controleer de afmeting van het gatpatroon van de TV/Monitor  
 Controllare le dimensioni dello schema di foratura della TV/del Monitor  
 TV/Monitör deliğinin ölçüsünü kontrol edin  
 检查电视/显示器孔眼形状尺寸

**Configuratie VESA-adapter**  
**Configurazioni di adattatore VESA**  
**VESA Adaptör Konfigürasyonları**  
**VESA 适配器配置**

De afmetingen van het gatpatroon van de TV/Monitor  
 Dimensioni dello schema di foratura della TV/del Monitor  
 TV/Monitör Delik Modeli Ölçüleri  
 电视/显示器孔眼形状尺寸

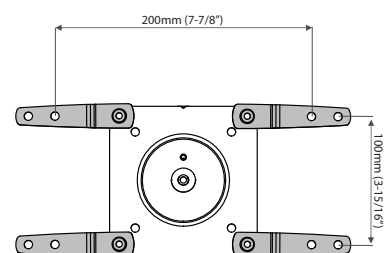
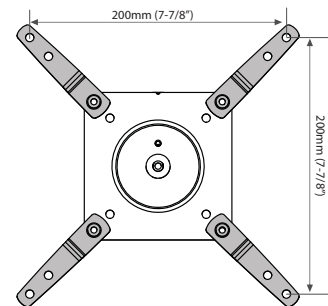
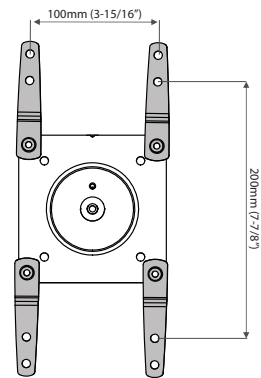
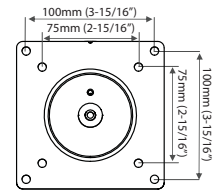
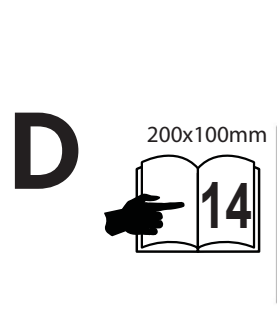
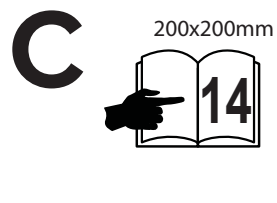
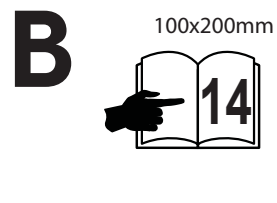
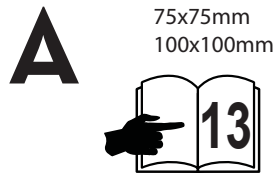

# A

Bevestig een TV/Monitor van het type A aan de arm  
Montare sul braccio una TV/un Monitor di tipo A  
Tip A TV/Monitörü Kola Monte Edin  
将 A 型电视/显示器安装到支臂

B, C, D  13

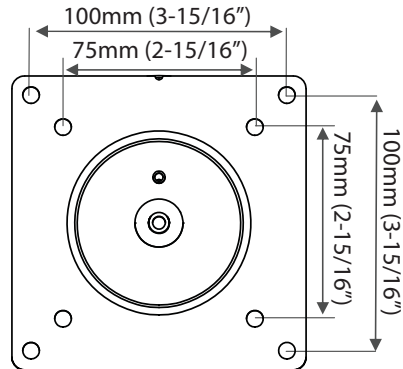

## 75 x 75mm

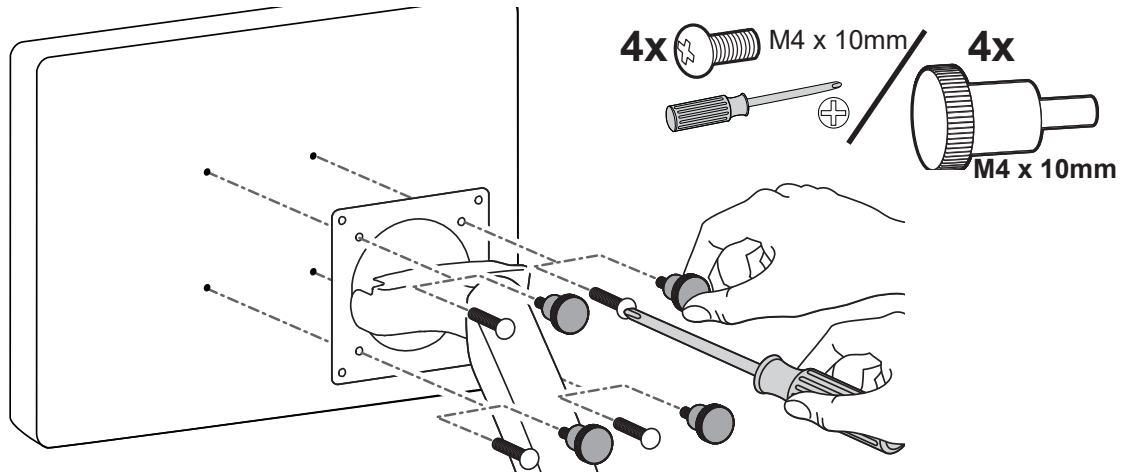
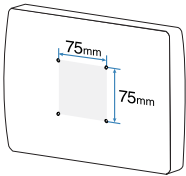

## 100 x 100mm

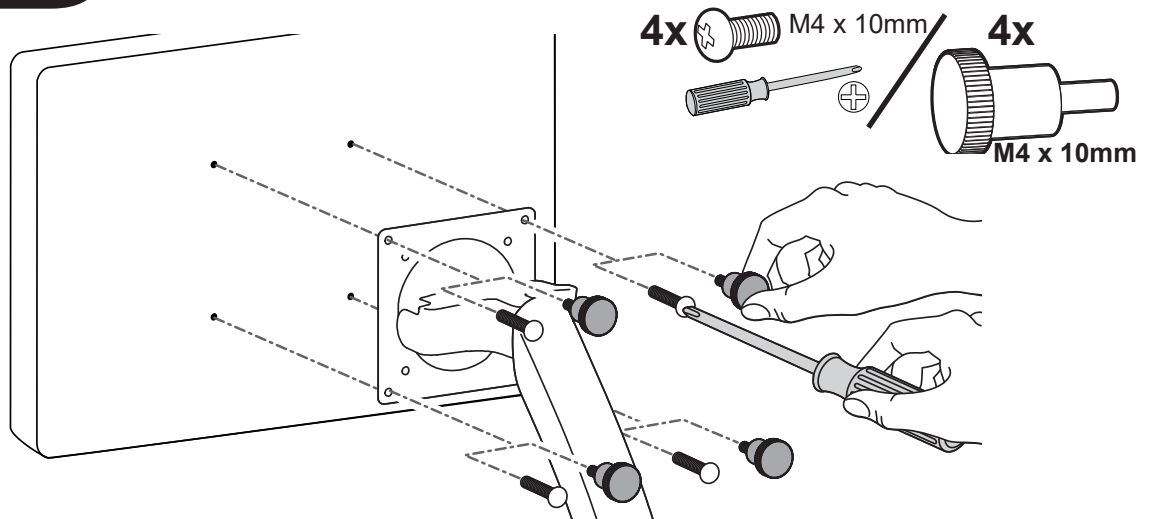
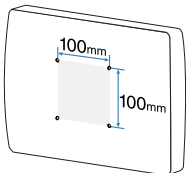

6  16

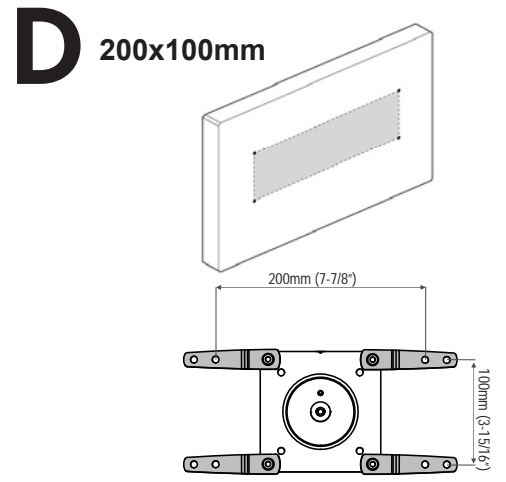
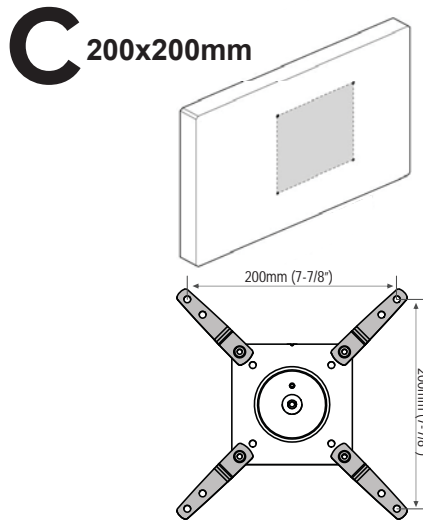
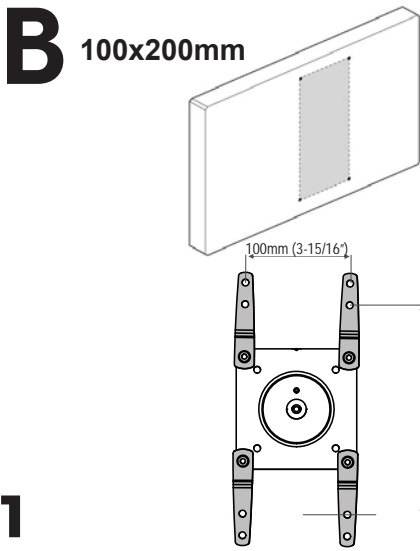

**1**

Bevestig de VESA-adapters aan de arm afhankelijk van de afmetingen van het TV/Monitor gatenpatroon (B, C of D).  
 Fissare gli adattatori VESA al braccio in base alle dimensioni dello schema di foratura della TV/del Monitor (B, C o D).  
 TV/Monitör delik ölçüsüne göre VESA Adaptörleri Kola Monte Edin (B, C veya D).  
 根据电视/显示器形状尺寸 (B、C 或 D)，将 VESA 适配器安装至支臂。

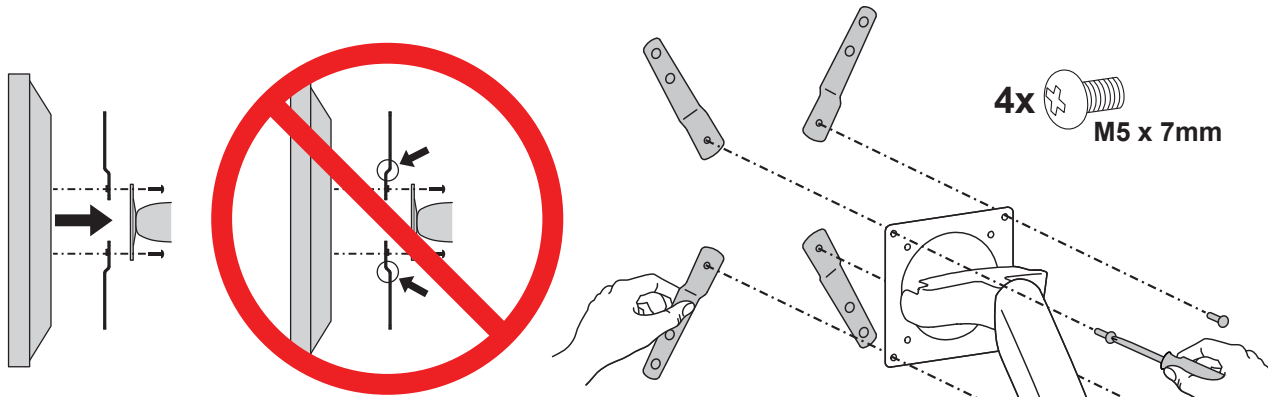

**2**

Bevestig een TV/Monitor van het type B, C of D aan de arm  
 Fissare al braccio la TV/il Monitor di tipo B, C o D  
 Tip B, C veya D TV/Monitörü Kola Monte Edin  
 将 B、C 或 D 型电视/显示器安装至支臂

LET OP: Om de M8 gaten kleiner te maken voor gebruik met M5 schroeven, of als u een model hebt met Samsung bevestigingsringen, volg dan de M8M5 KIT instructies op de volgende pagina.

NOTA: Per ridurre i fori M8 in modo da utilizzarli con viti M5, oppure se si dispone di un modello con anelli di ritenuta Samsung, seguire le istruzioni KIT M8M5 riportate alla pagina seguente.

NOT: M5 vidalarla kullanmak üzere M8 deliklerini küçültmek için veya Samsung tutucu halkalarına sahip bir modeliniz var ise sonraki sayfada yer alan M8M5 SETİ talimatlarına bakınız.

注：为缩小 M8 孔眼以使用 M5 螺丝或如果您的机型带有 Samsung 固定环，请按照下页的 M8M5 套件说明进行操作。

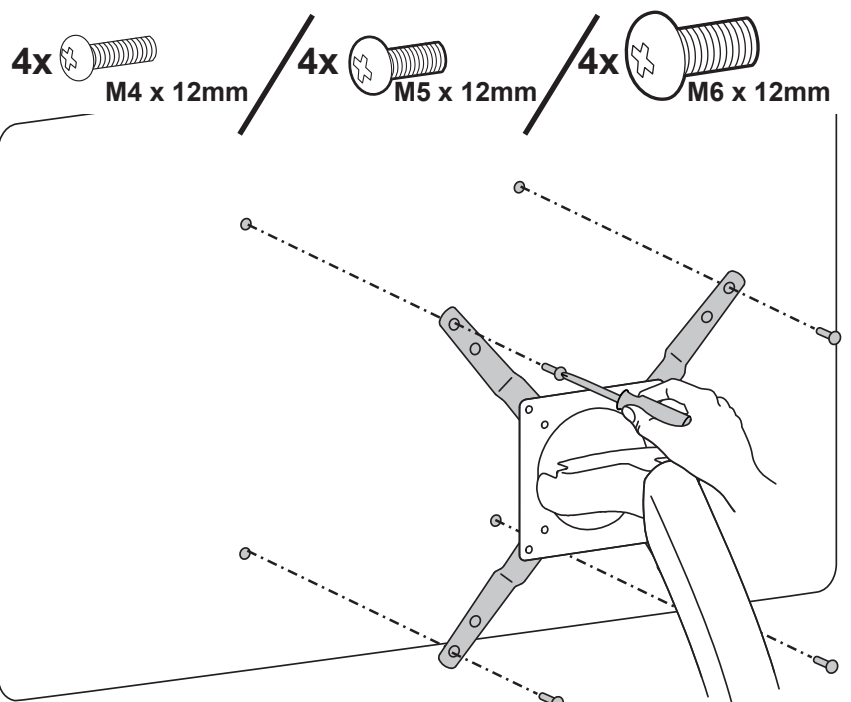

Instructies voor de M8M5 KIT  
Istruzioni KIT M8M5  
M8M5 SETİ Talimatları  
M8M5 套件说明

**OPMERKING:** Volg deze stap wanneer uw tv/monitor voorzien is van gaten met diameter M8 die verkleind moeten worden tot diameter M5.

Installeer een verloopbus M8M5 aan de tv/monitor en gebruik de M5 x 20 mm-schroeven om de monitor vast te zetten.

**NOTA:** eseguire questo passaggio soltanto se la TV/il monitor presenta fori M8 da ridurre a M5.

Installare una boccola di riduzione M8M5 alla TV/al monitor e utilizzare viti per monitor M5 x 20 mm per fissare.

**NOT:** Bu adımı sadece TV/monitörünüzün, M5 olarak küçültülmesi gereken M8 deliklerine sahip olması halinde uygulayın.

TV/Monitöre M8M5 küçültücü burç yerleştirin ve sabitlemek için M5 x 20 mm monitör vidaları kullanın.

注意：仅当您的电视/监视器的 M8 孔需要缩减为 M5 孔时，才需执行此步骤。

将 M8M5 减速器套管安装到电视/监视器上，并使用 M5 x 20 mm 监视器螺丝固定。

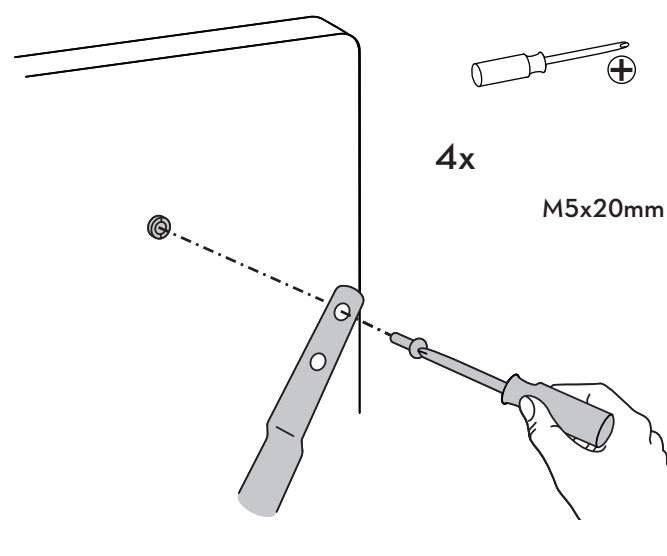
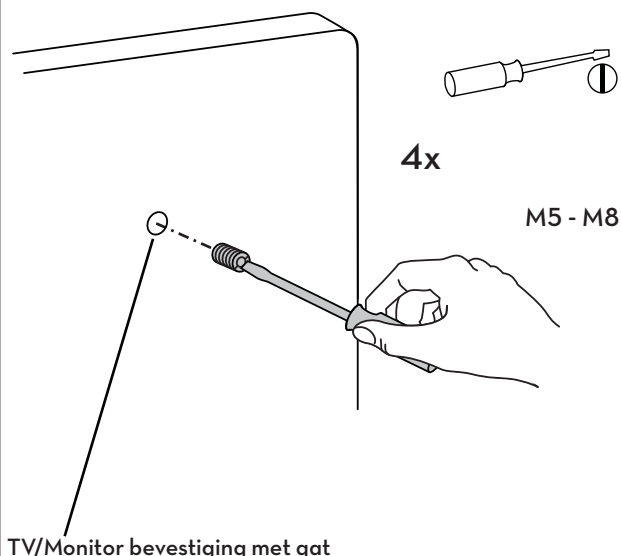

TV/Monitor bevestiging met gat met M8 maat.

Foro di dimensioni M8 per il montaggio di TV/Monitor

TV/Monitör Montajı

装有 M8 尺寸孔眼的电视/显示器。

**OPMERKING:** Volg deze stap enkel voor modellen van Samsung die de bevestigingsring gebruiken.  
Installeer een verloopbus M8M5 aan de tv/monitor en gebruik daarna de M5 x 20 mm-schroeven en de bevestigingsring van Samsung om de monitor vast te zetten.

**NOTA:** eseguire questo passaggio solo per i modelli Samsung che utilizzano l'anello di ritenuta.  
Installare una boccola di riduzione M8M5 alla TV/al monitor, quindi utilizzare viti per monitor M5 x 20 mm per fissare.

**NOT:** Bu adımı sadece tutma halkasına sahip Samsung modeller için uygulayın.

TV/Monitöre M8M5 küçültücü burç yerleştirin ve sabitlemek için M5 x 20 mm monitör vidaları ve Samsung tutma halkası kullanın.

注意：此步骤仅适用于使用固定环的三星机型。

将 M8M5 减速器套管安装到电视/监视器上，然后使用 M5 x 20 mm 监视器螺丝和三星固定环固定。

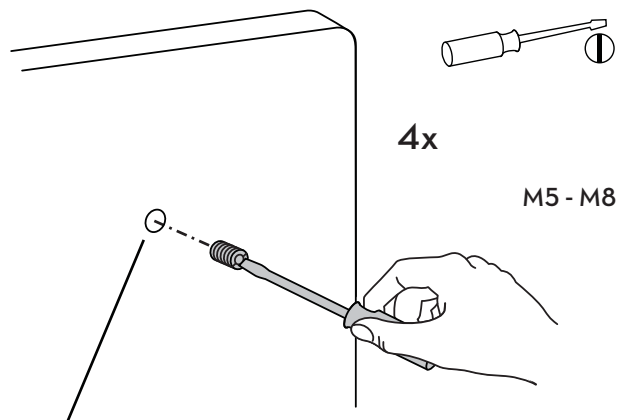

TV/Monitor bevestiging met gat met M8 maat.

Foro di dimensioni M8 per il montaggio di TV/Monitor

TV/Monitör Montajı

装有 M8 尺寸孔眼的电视/显示器。

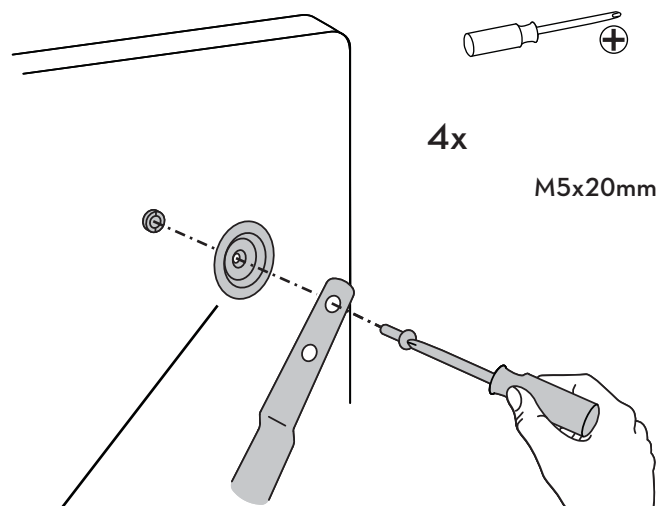

Bevestigingsring (niet bijgeleverd "Alleen voor Samsung")

Anello di ritenuta (non in dotazione \*Soltanto Samsung)

Tutma Halkası (Dahil değil \*Sadece Samsung)

固定环 (不包含, 仅限 \*Samsung)



6

a

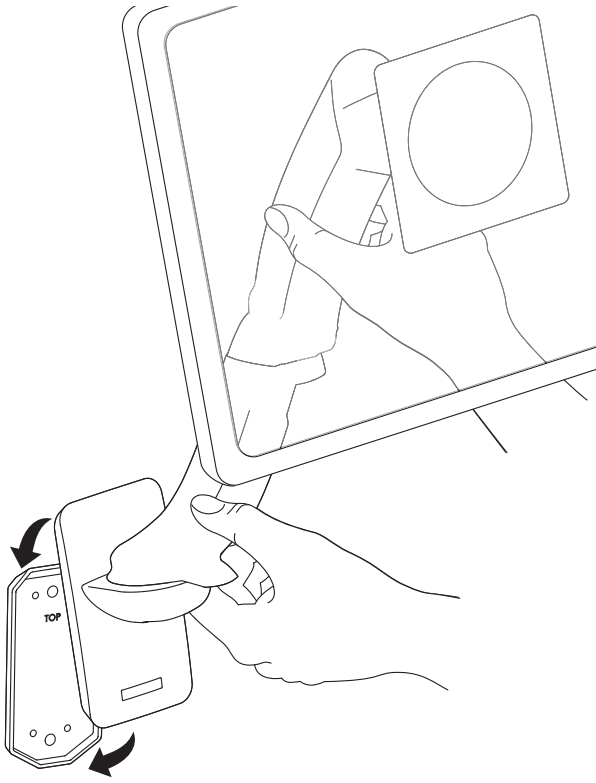

b

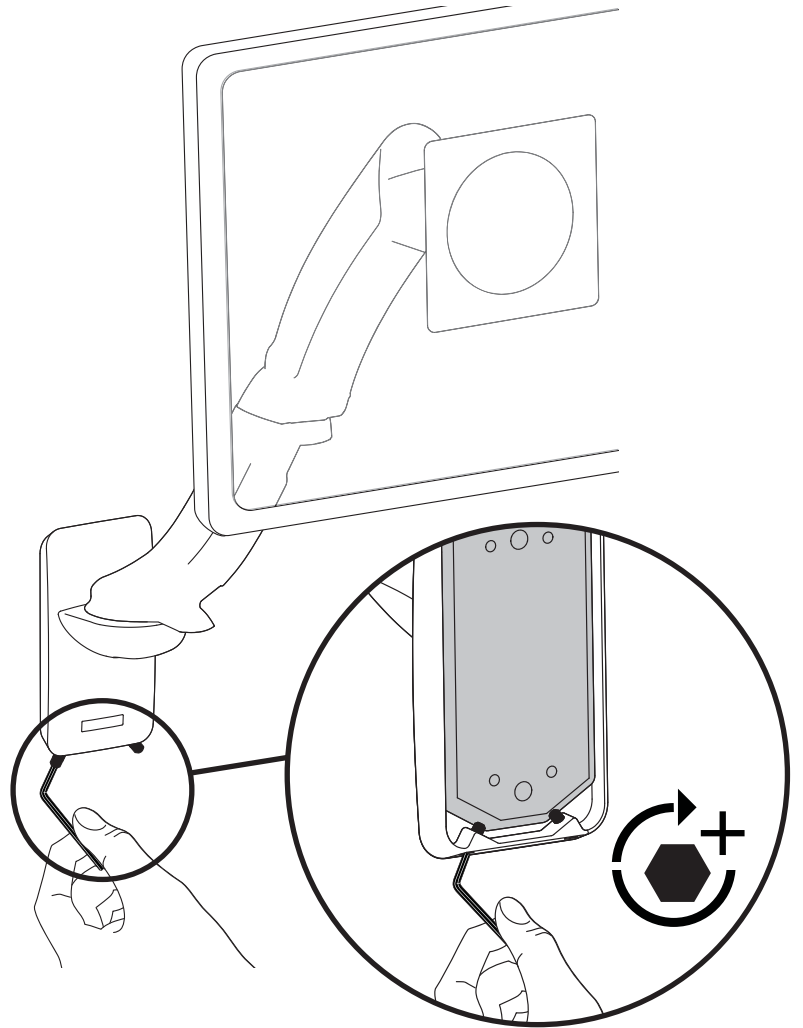



**LET OP:** Laat voldoende speling in de kabel om volledige bewegingsbereik mogelijk te maken.



Voorzichtig: Om te voorkomen dat de snoeren mogelijk beklemd raken, dient u de instructies voor het leiden van de snoeren in dit handboek te volgen. Nalaten deze instructies te volgen kan de apparatuur beschadigen of persoonlijk letsel veroorzaken.



**NOTA:** Lasciare sufficiente gioco per consentire al cavo l'intero intervallo di movimento.



Attenzione: Per evitare la possibilità di schiacciare i cavi, è importante seguire le istruzioni di instradamento dei cavi riportate nel presente manuale. La mancata osservanza delle presenti istruzioni può causare danni alle cose o infortuni personali.



**NOT:** Tam bir hareket olanağı sağlamak için kabloyu yeterince gevşek bırakın.



Dikkat: Kablolarda sıkışma olasılığını önlemek için bu el kitabındaki kablo yönlendirme talimatlarına uymak önemlidir. Bu talimatlara uyulmaması donanımda hasar ve/veya kişisel yaralanmayla sonuçlanabilir!



**注:** 保持线缆有足够的松弛度以便全方位移动。



小心: 为了避免夹住线缆, 请务必遵守本手册中的布线说明。不遵守本警告指示可能导致设备损坏或人身伤害。

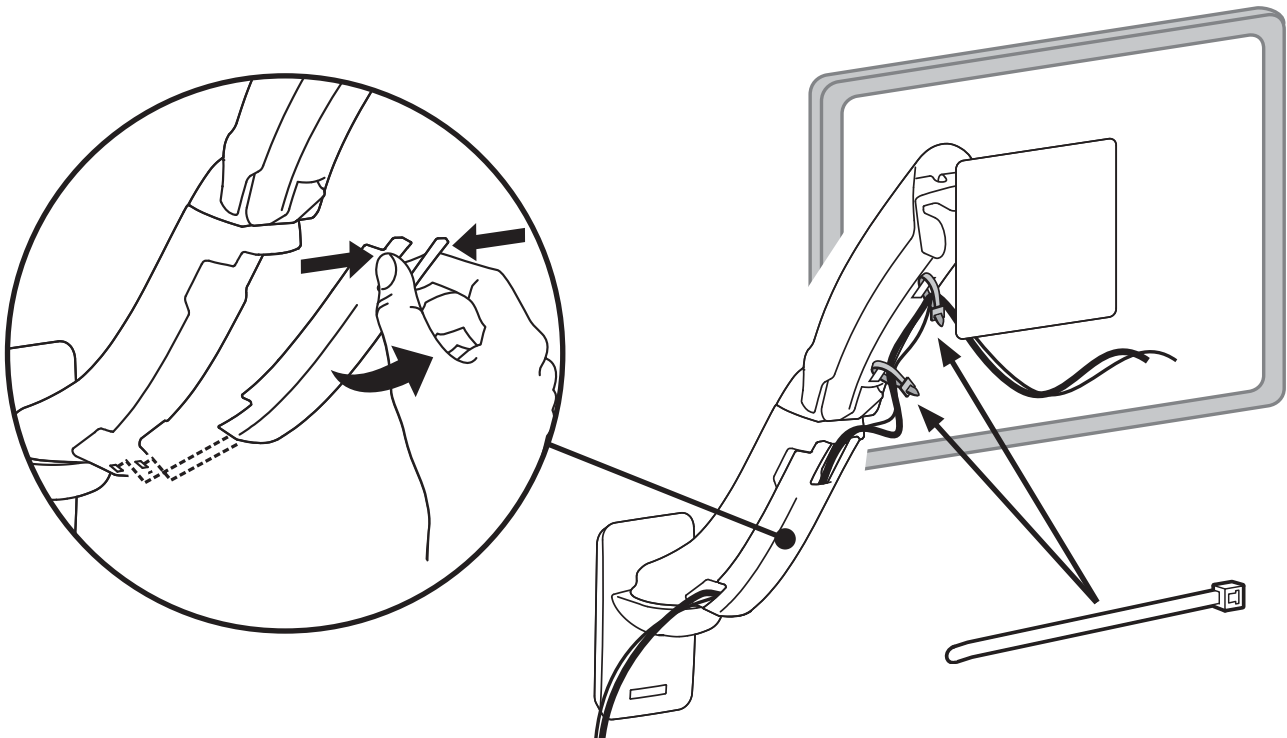

8



Belangrijk! U moet dit product bijstellen nadat de installatie voltooid is. Overtuig u ervan dat al uw apparatuur op de juiste wijze geïnstalleerd is op het product voordat u probeert bijstellingen uit te voeren. Dit product moet soepel en makkelijk bewegen door alle bewegingen en blijven staan waar u het zet. Als het te makkelijk of moeilijk beweegt of als het product niet in de gewenste posities blijft staan, volg dan de instructies voor het bijstellen om te zorgen voor soepele en makkelijke bewegingen. Afhankelijk van uw product en de bijstelling moet u mogelijk veel aan de schroeven en knoppen draaien om een verschil te merken. Elke keer als apparatuur toegevoegd of verwijderd wordt van dit product met als resultaat een verandering in het gewicht van de gemonteerde belasting, moet u deze stappen voor bijstelling opnieuw doorlopen om te zorgen voor een veilige en beste werking.

Importante! Al termine dell'installazione, sarà necessario regolare questo prodotto. Verificare che tutte le apparecchiature siano correttamente installate sul prodotto, prima di cercare di eseguire le regolazioni. Questo prodotto deve spostarsi in modo uniforme e scorrevole attraverso l'intero raggio di movimento, nonché restare fermo nel punto in cui viene collocato. Se gli spostamenti appaiono troppo agevoli o troppo difficili, oppure se il prodotto non resta nelle posizioni previste, attenersi alle istruzioni sulla regolazione per ottenere spostamenti uniformi e scorrevoli. In base al prodotto e alla regolazione, è possibile che siano necessari molti giri per notare la differenza. Ogni volta che si aggiungono o tolgono apparecchiature dal prodotto, determinando una modifica nel peso del carico montato, occorre ripetere questi passaggi di regolazione, per garantire un funzionamento sicuro e ottimale.

Önemli! Montaj tamamlandıktan sonra bu ürün ayarlamamız gerekecektir. Ayarlamalar yapmadan önce tüm donanımınızın ürün üzerine düzgün şekilde monte edildiğinden emin olun. Bu ürün tüm hareket alanı boyunca düzgünce ve kolayca hareket etmeli ve ayarladığınız yerde kalmalıdır. Eğer hareketler çok kolay veya çok zorsa ya da ürün istenen konumlarda durmuyorsa, düzgün ve kolay hareketler oluşturmak için ayar talimatlarını izleyin. Ürünüze ve ayara bağlı olarak bir farkın tespiti için birçok dönüş gerekebilir. Monte edilen yükün ağırlığında bir değişikliğe yol açacak bir donanımı bu ürün üzerine eklediğiniz veya çıkardığınız zaman güvenli ve en uygun çalışmayı sağlamak üzere bu ayar adımlarını tekrarlamalısınız.

重要说明！本产品安装完成后需要调节。在尝试进行调节之前，确保所有设备都正确安装在产品上。本产品应能在整个动作范围内灵活自如地移动，并能固定在所设定的位置。如果移动过于容易或过于困难，或者产品不能固定在想要的位置上，请按照调节说明操作，使动作灵活自如。根据您的所用产品及调节方式，可能需要旋转几圈后才能注意到差别。每次添加或者从本产品上拆除设备时，都会使安装负荷重量发生变化，您应该重复调节步骤，确保运行状态安全、最佳。

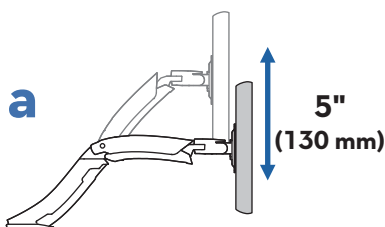

### Verstel in hoogte - Omhoog en omlaag

#### Sollevamento - Su e Giù

#### Kaldırın - Yukarı ve aşağı

#### 升降 (上下)

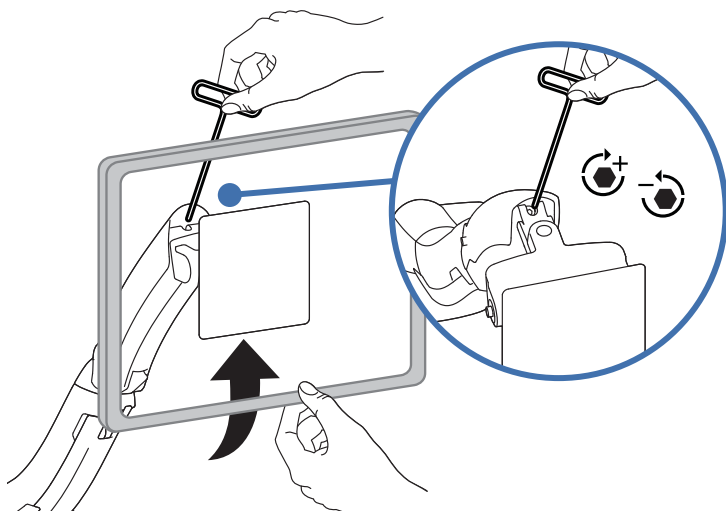

De tilsterkte verhogen  
Als het geïnstalleerde gewicht te zwaar is of als dit product niet omhoog blijft staan als het omhoog getild is, moet u de tilsterkte verhogen.

Aumentare la potenza di sollevamento  
Se il carico montato è eccessivo o se questo prodotto non rimane su dopo essere stato sollevato, occorre aumentare la potenza di sollevamento.

Kaldırma Gücünü Artırın  
Monte edilen ağırlık çok fazlaysa veya bu ürün yükseltildiği zaman yukarıda durmuyorsa, bu durumda Kaldırma Gücünü artırmanız gerekecektir:

增大升力  
如果安装重量过重，或者升起本产品时，产品不停留在升起位置，那么您需要增大升力：



De tilsterkte verlagen  
Als het geïnstalleerde gewicht te licht is of als dit product niet omlaag blijft staan als het naar beneden geduwd is, moet u de tilsterkte verlagen.

Diminuire la potenza di sollevamento  
Se il carico montato è troppo leggero o se questo prodotto non rimane giù dopo essere stato abbassato, occorre ridurre la potenza di sollevamento.

Kaldırma Gücünü Azaltın  
Monte edilen ağırlık çok azsa veya bu ürün alçaltıldığı zaman aşağıda durmuyorsa, bu durumda Kaldırma Gücünü azaltmanız gerekecektir:

减小升力  
如果安装重量过轻，或者降下本产品时，产品不停留在降下位置，那么您需要减小升力：

**b** Kantel - Naar voren en naar achteren  
 Inclinazione - Avanti ed Indietro  
 Eğin - Öne ve Geriye  
 倾斜 - 前后

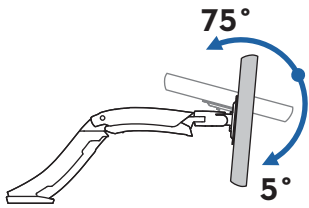

De tilsterkte verhogen  
 Als het geïnstalleerde gewicht te zwaar is of als dit product niet omhoog blijft staan als het omhoog getild is, moet u de tilsterkte verhogen.

Aumentare la potenza di sollevamento  
 Se il carico montato è eccessivo o se questo prodotto non rimane su dopo essere stato sollevato, occorre aumentare la potenza di sollevamento.

Kaldırma Gücünü Artırın  
 Monte edilen ağırlık çok fazlaysa veya bu ürün yükseltildiği zaman yukarıda durmuyorsa, bu durumda Kaldırma Gücünü artırmanız gerekecektir:

增大升力  
 如果安装重量过重，或者升起本产品时，产品不停留在升起位置，那么您需要增大升力：



De tilsterkte verlagen  
 Als het geïnstalleerde gewicht te licht is of als dit product niet omlaag blijft staan als het naar beneden geduwd is, moet u de tilsterkte verlagen.

Diminuire la potenza di sollevamento  
 Se il carico montato è troppo leggero o se questo prodotto non rimane giù dopo essere stato abbassato, occorre ridurre la potenza di sollevamento.

Kaldırma Gücünü Azaltın  
 Monte edilen ağırlık çok azsa veya bu ürün alçaltıldığı zaman aşağıda durmuyorsa, bu durumda Kaldırma Gücünü azaltmanız gerekecektir:

减小升力  
 如果安装重量过轻，或者降下本产品时，产品不停留在降下位置，那么您需要减小升力：

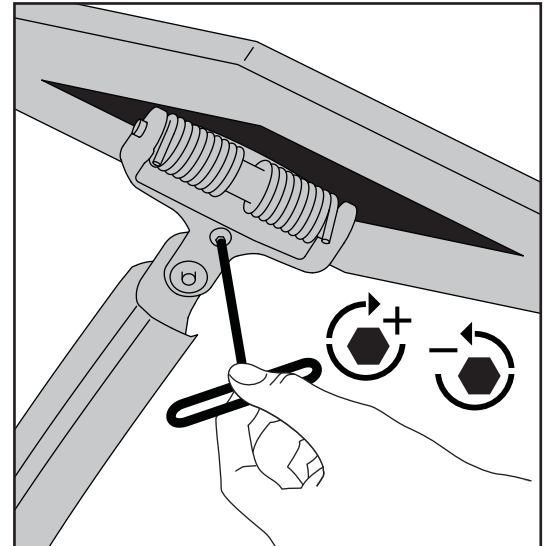
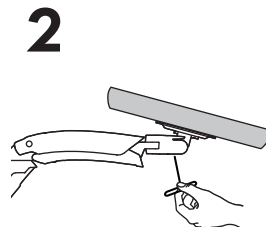
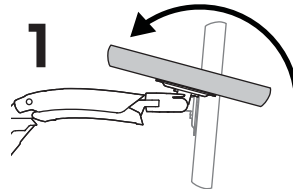

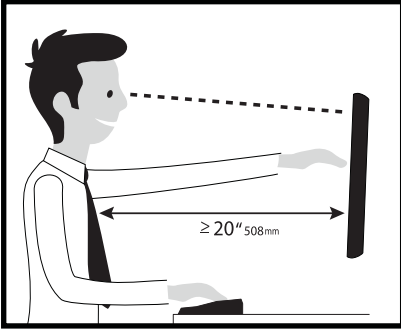

Learn more about ergonomic computer use at: [www.ergotron.com/ergonomics](http://www.ergotron.com/ergonomics)

**NL** De nieuwste Gids voor installatie door de gebruiker kunt u vinden op: [www.ergotron.com](http://www.ergotron.com)  
Ga voor garantie naar: [www.ergotron.com/warranty](http://www.ergotron.com/warranty)  
Ga voor service naar: [www.ergotron.com](http://www.ergotron.com)  
Plaatselijke telefoonnummers voor de klantendienst kunt u vinden op: <http://contact.ergotron.com>

**IT** Per la versione più recente della Guida all'installazione per l'utente, visitare il sito web: [www.ergotron.com](http://www.ergotron.com)  
Per la garanzia visitare: [www.ergotron.com/warranty](http://www.ergotron.com/warranty)  
Per assistenza visitare: [www.ergotron.com](http://www.ergotron.com)  
Per conoscere i numeri di telefono dell'assistenza clienti locale, visitare: <http://contact.ergotron.com>

**TR** En yeni Kullanım Kılavuzu sürümü için lütfen [www.ergotron.com](http://www.ergotron.com) adresini ziyaret ediniz.  
Garanti için [www.ergotron.com/warranty](http://www.ergotron.com/warranty) adresini ziyaret edin  
Servis için [www.ergotron.com](http://www.ergotron.com) adresini ziyaret edin  
Yerel müşteri destek telefon numaraları için <http://contact.ergotron.com> adresini ziyaret edin

**ZH** 若需最新的用户安装指南，请访问：[www.ergotron.com](http://www.ergotron.com)  
为保证参观：[www.ergotron.com/warranty](http://www.ergotron.com/warranty)  
对于上门服务：[www.ergotron.com](http://www.ergotron.com)  
若需当地客户服务电话号码，请访问：<http://contact.ergotron.com>

# ergotron®

[www.ergotron.com](http://www.ergotron.com) | USA: 1-800-888-8458 | Europe: +31 (0)33-45 45 600 | China: 400-120-3051 | Japan: [japansupport@ergotron.com](mailto:japansupport@ergotron.com)

© 2016 Ergotron, Inc. All rights reserved.

While Ergotron, Inc. makes every effort to provide accurate and complete information on the installation and use of its products, it will not be held liable for any editorial errors or omissions (including those made in the process of translation from English to another language), or for incidental, special or consequential damages of any nature resulting from furnishing this instruction and performance of equipment in connection with this instruction. Ergotron, Inc. reserves the right to make changes in the product design and/or product documentation without notification to its users. For the most current product information, or to know if this document is available in languages other than those herein, please contact Ergotron. No part of this publication may be reproduced, stored in a retrieval system, or transmitted in any form or by any means, electronic, mechanical, photocopying, recording or otherwise without the prior written consent of Ergotron, Inc., 1181 Trapp Road, Eagan, Minnesota, 55121, USA. Patents Pending and Patented U.S. & Foreign. Ergotron is a registered trademark of Ergotron, Inc.