

ergotron®

MX mini Desk Mount LCD Arm

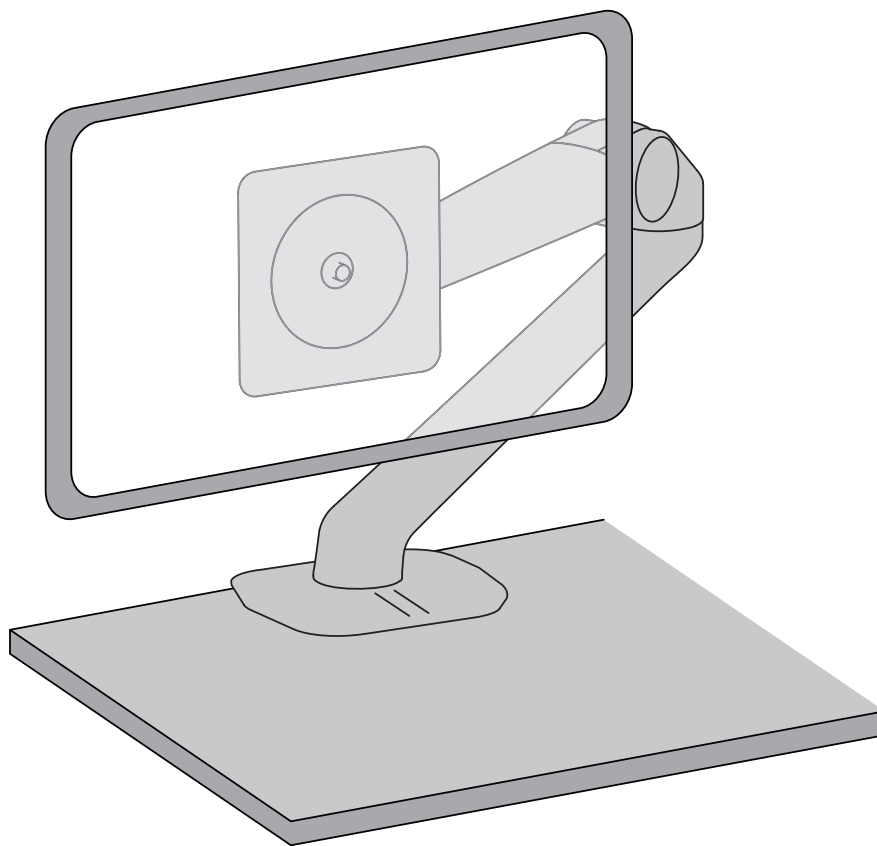

Tools Needed

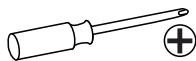

For Grommet Hole
Mounting

Ø 5/16" (8 mm)



Ø 3/8" (9.5 mm)



English



For the latest User Installation Guide please visit: www.ergotron.com





English, Español, Français, Deutsch, Nederlands, Italiano, Svenska, 日本語, 汉语

www.ergotron.com | USA: 1-800-888-8458 | Europe: +31 (0)33-45 45 600 | China: 400-120-3051 | Japan: japansupport@ergotron.com

Hazard Symbols

Review

These symbols alert users of a safety condition that demands attention. All users should be able to recognize and understand the significance of the following Safety Hazards if encountered on the product or within the documentation. Children who are not able to recognize and respond appropriately to Safety Alerts should not use this product without adult supervision!







| Symbol | Signal Word | Level of Hazard |
|---|-------------------|---|
|  | NOTE | A NOTE indicates important information that helps you make better use of this product. |
|  | CAUTION | A CAUTION indicates either potential damage to hardware or loss of data and tells you how to avoid the problem. |
|  | WARNING | A WARNING indicates either potential for property damage, personal injury, or death. |
|  | ELECTRICAL | An Electrical indicates an impending electrical hazard which, if not avoided, may result in personal injury, fire and/or death. |

Safety

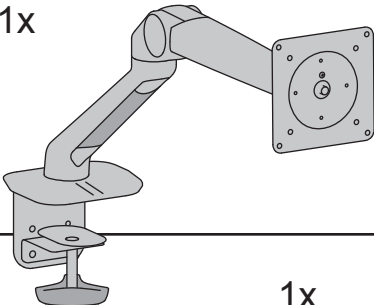
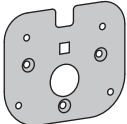
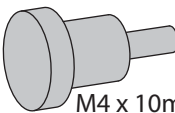
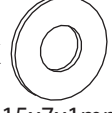
 **Warning:** Because mounting surface materials can vary widely, it is imperative that you make sure mounting surface is strong enough to handle mounted product and equipment.

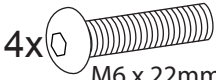
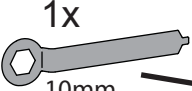
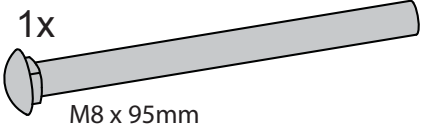
 **Caution:** To avoid the potential to pinch cables it is important to follow the cable routing instructions in this manual. Failure to follow these instructions may result in equipment damage or personal injury.

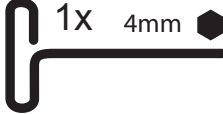
Components

| | A | B | C | D |
|---|--|---|--|--|
| 1 | 1x  | 1x  | 4x  M4 x 10mm | 4x  15x7x1mm |
| 2 | | 2x  | 4x  M4 x 10mm | 4x  M6 x 22mm |
| 3 | | 1x  10mm | 1x  M8 x 95mm | |
| 4 | | | 1x  M8 | 2x  M6 x 16mm |
| 5 | | | 1x  4mm | 1x  3mm |

Features & Specifications

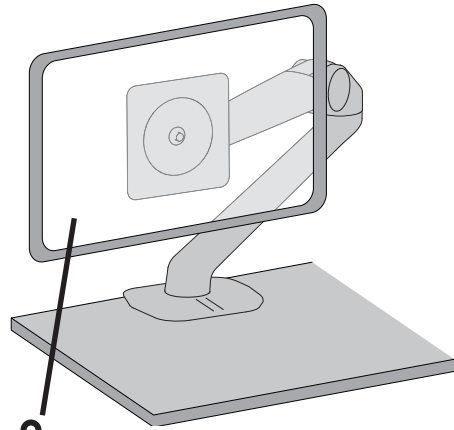
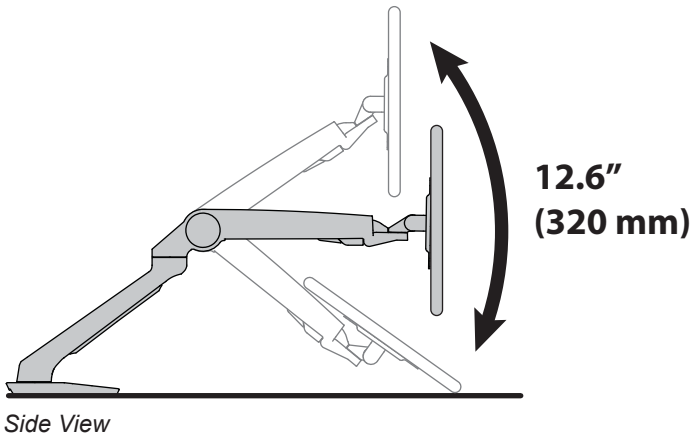

LB
kg ≤ 8 lbs. (3.6 kg)

CAUTION: DO NOT EXCEED MAXIMUM LISTED WEIGHT CAPACITY. SERIOUS INJURY OR PROPERTY DAMAGE MAY OCCUR!

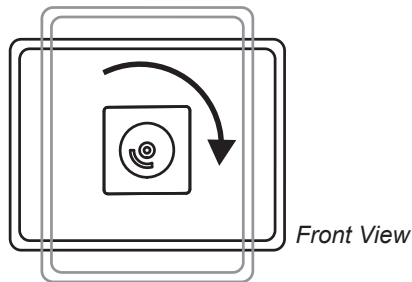
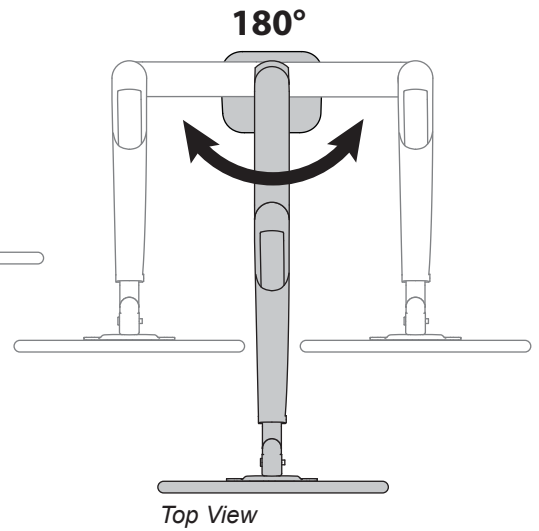
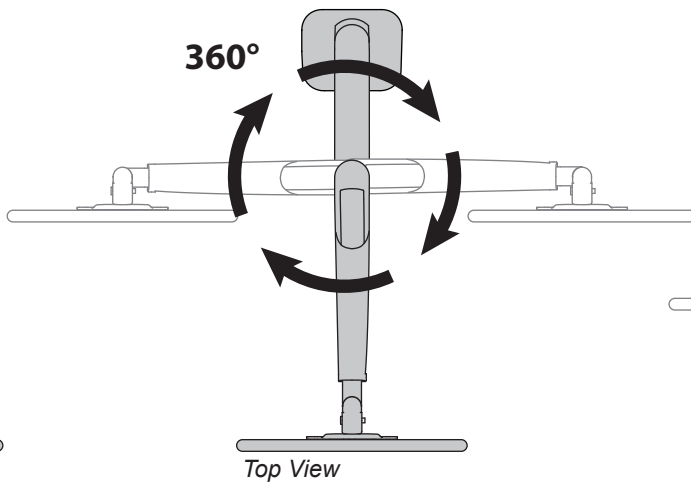
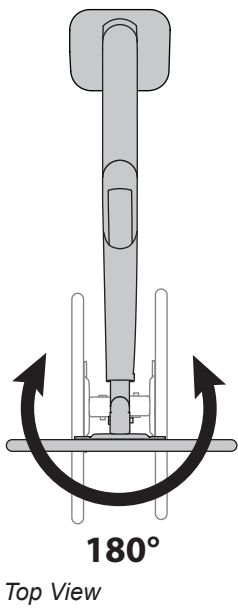
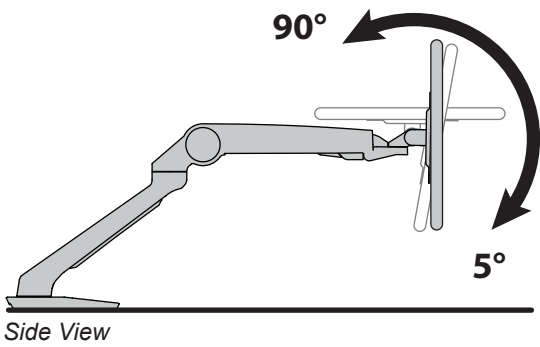

Portrait/Landscape Rotation.

1

Choose 1 of the 3 Mounting Options:

CLAMP

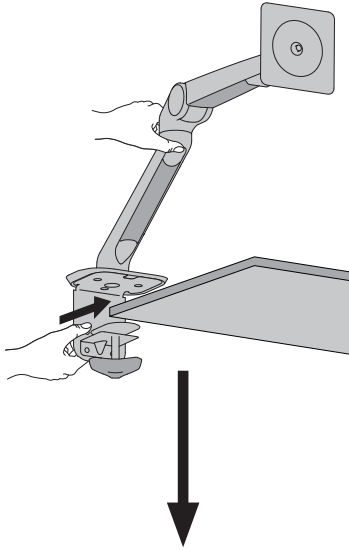

GROMMET HOLE

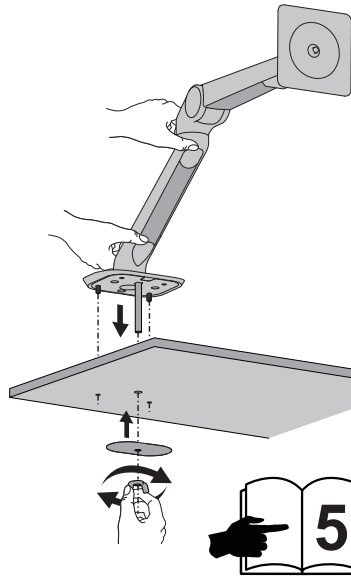

Ergotron WorkFit-T

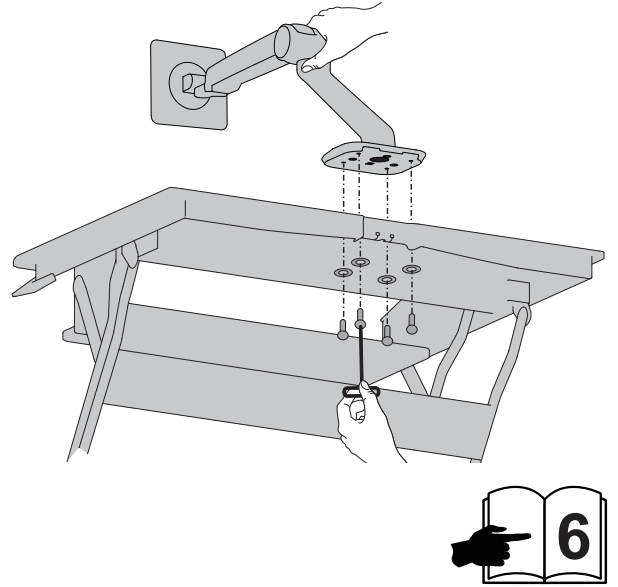

a

1.27"-2.35"
(32-60 mm)

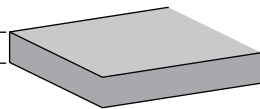

0.28"-1.36"
(7-35 mm)

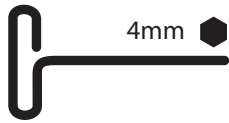
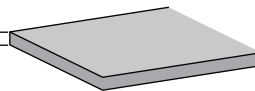

4mm

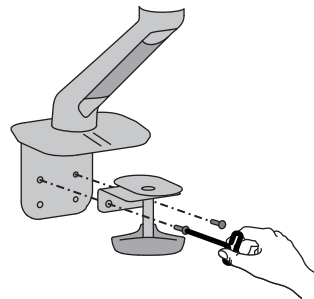
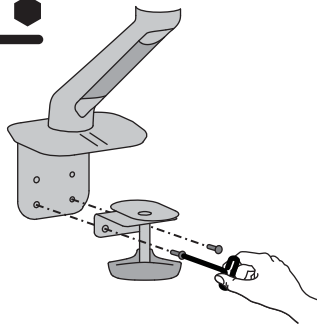

b

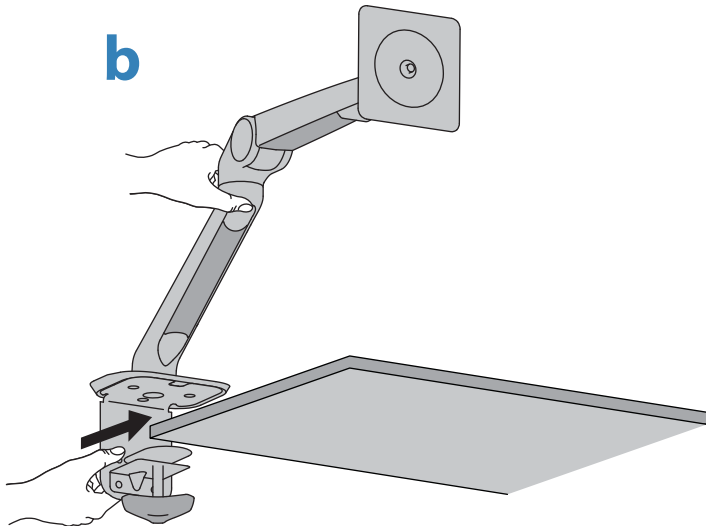

c

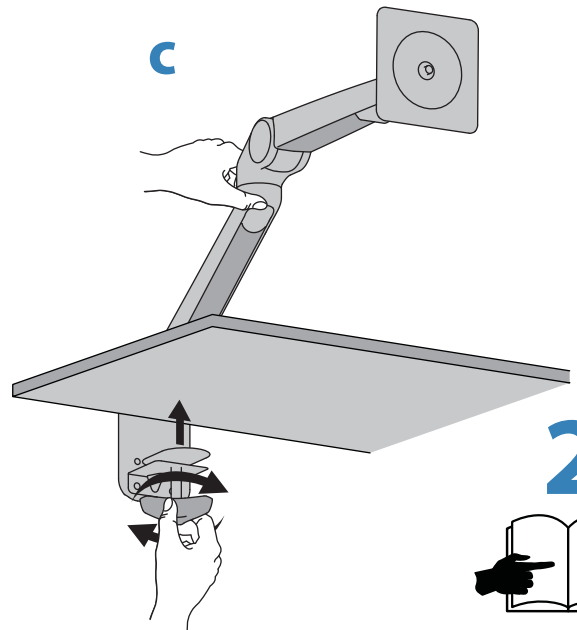

GROMMET HOLE

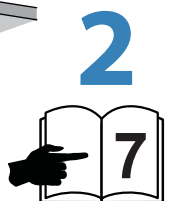
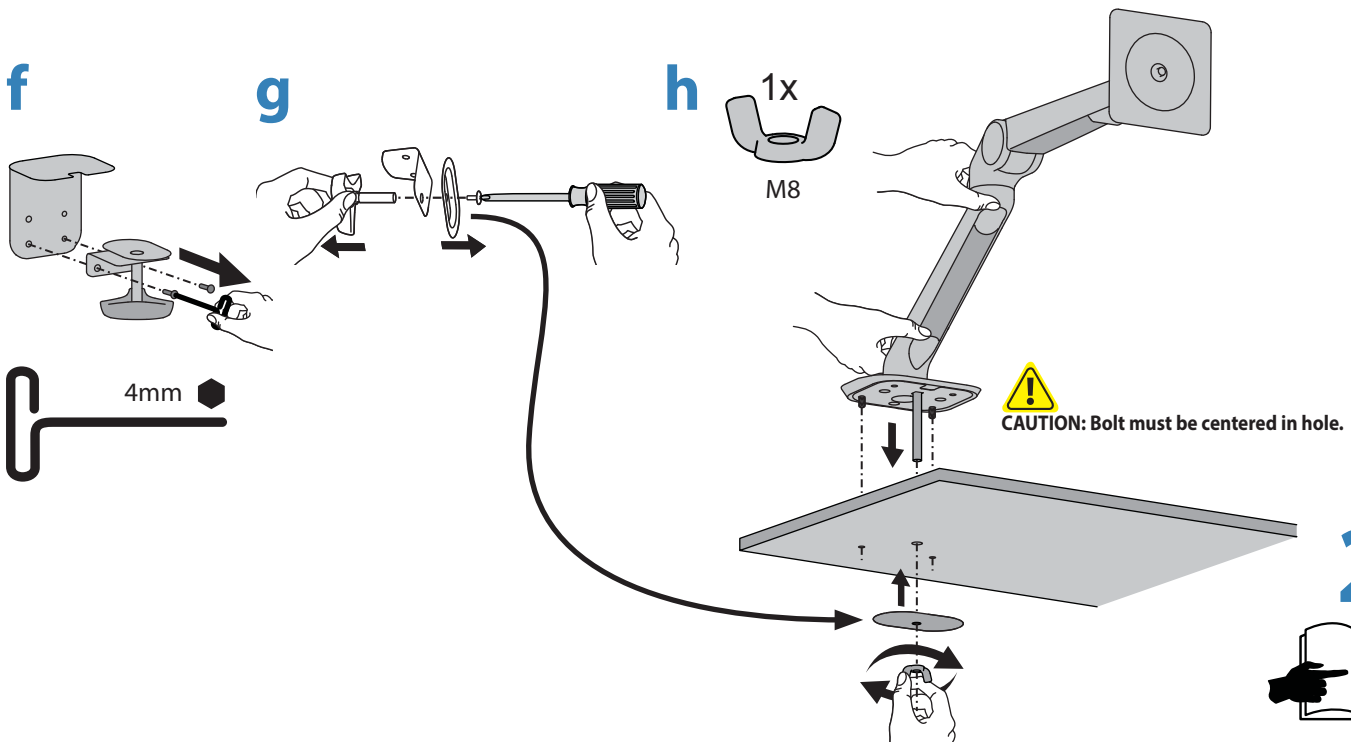
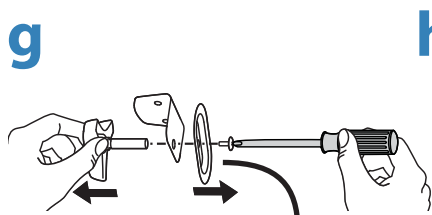
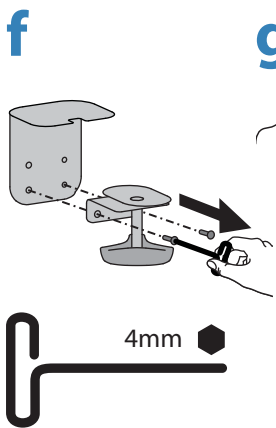
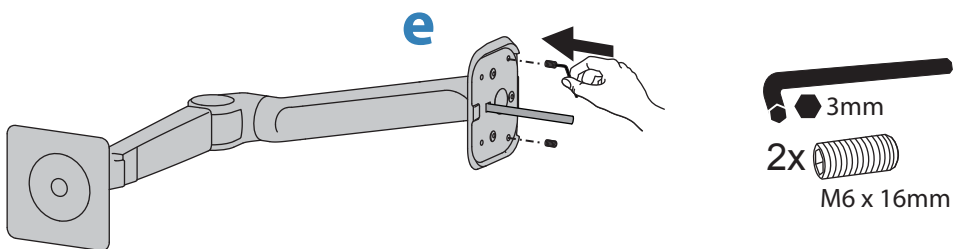
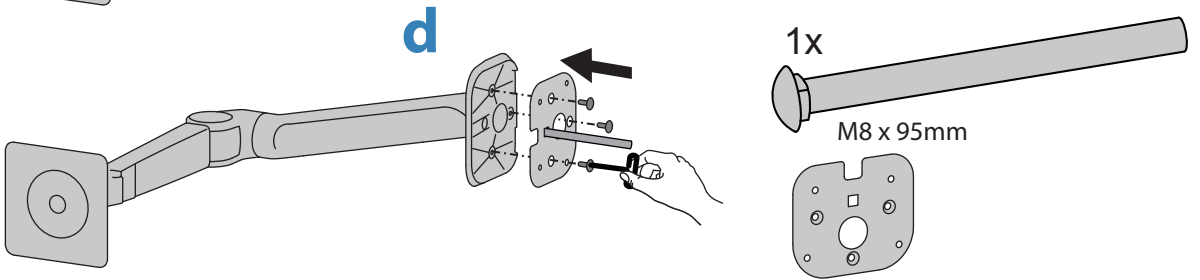
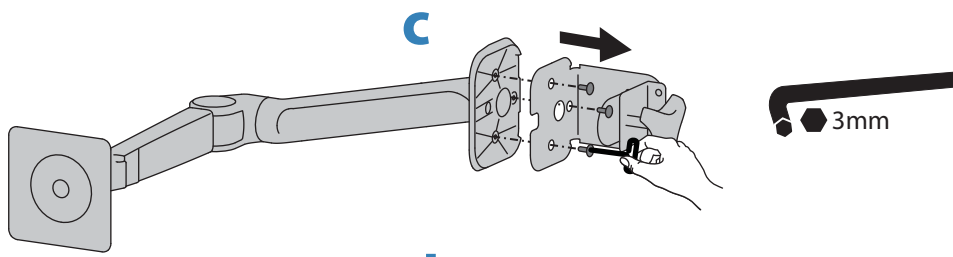
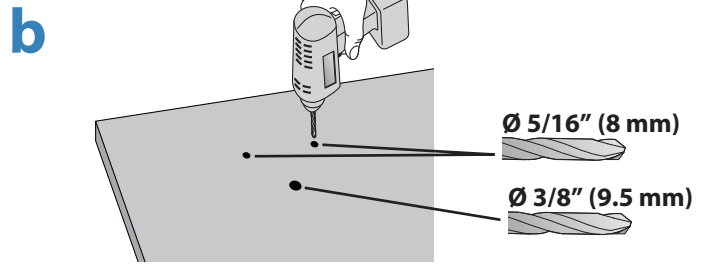
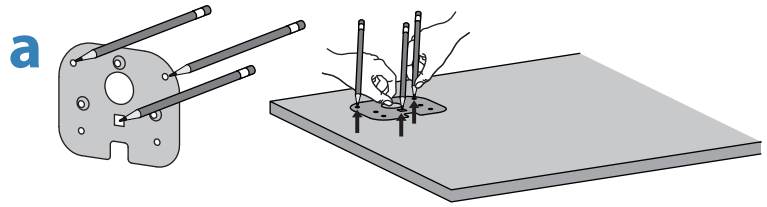
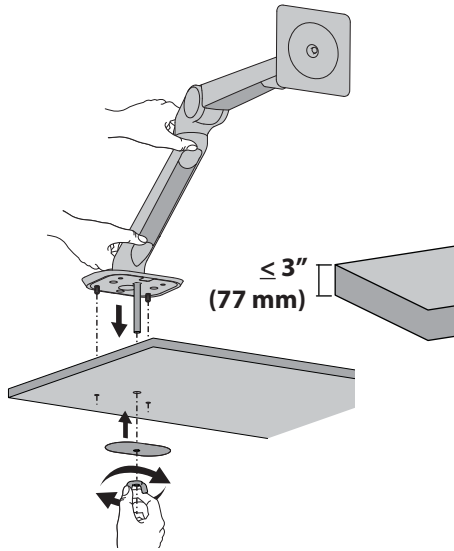

Ergotron WorkFit-T

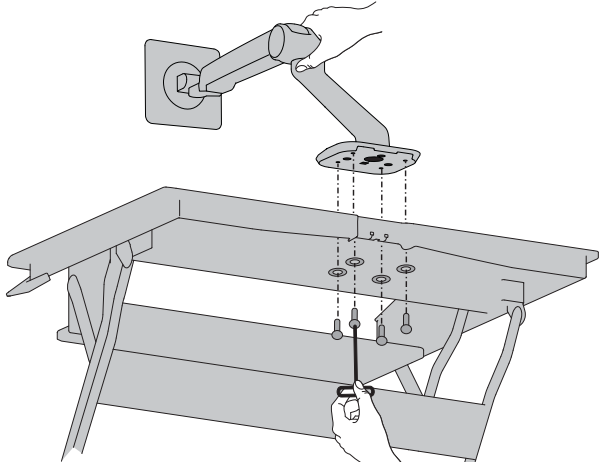

a

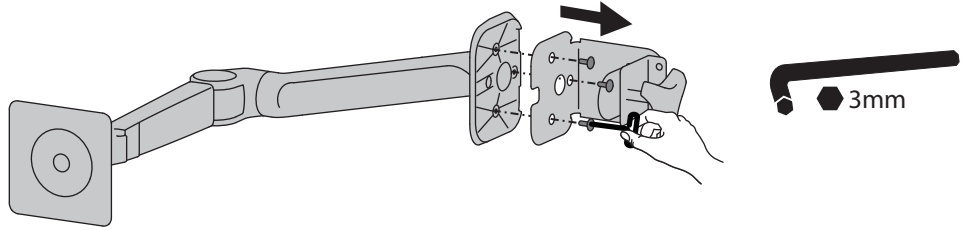

b

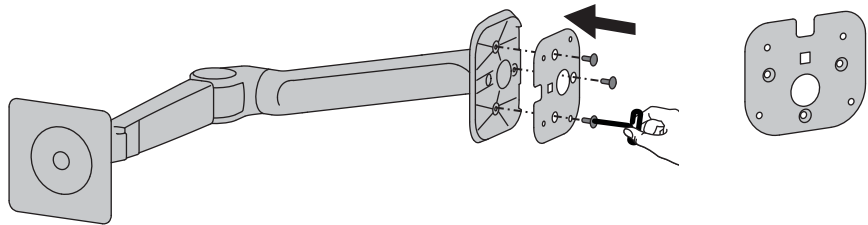

c

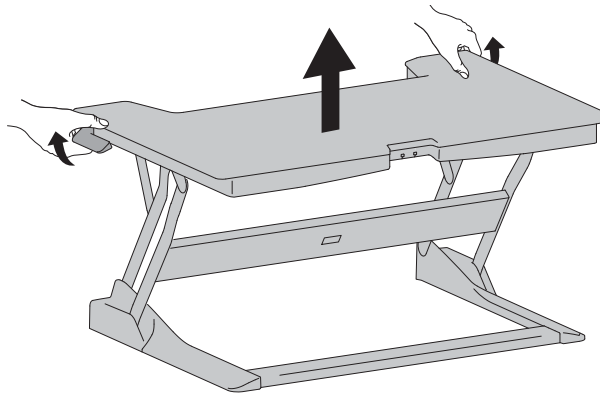

d

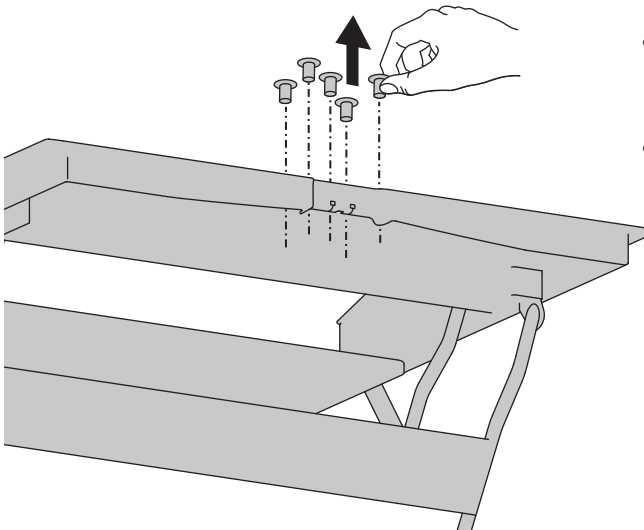

e

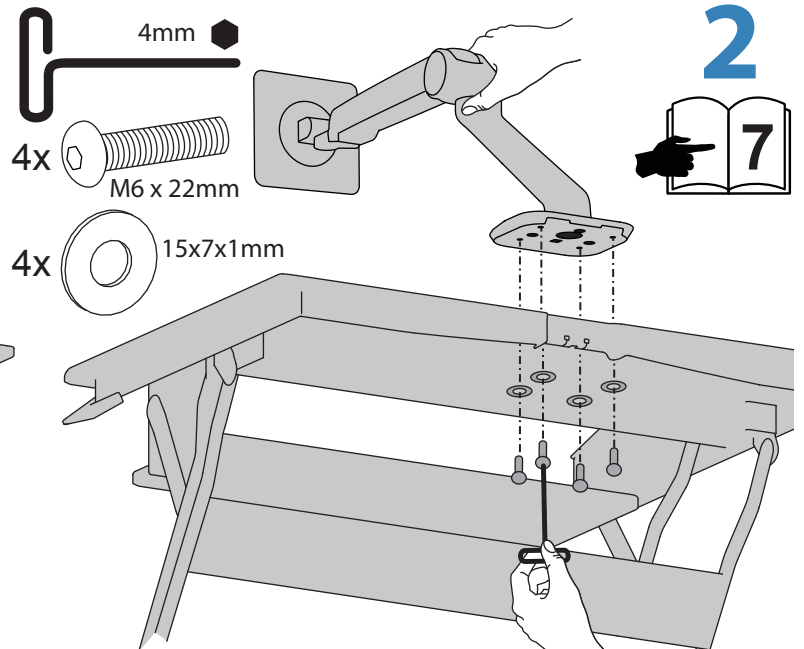

2 Attach Display

Remove Stop Screw if you would like Portrait/Landscape Rotation.

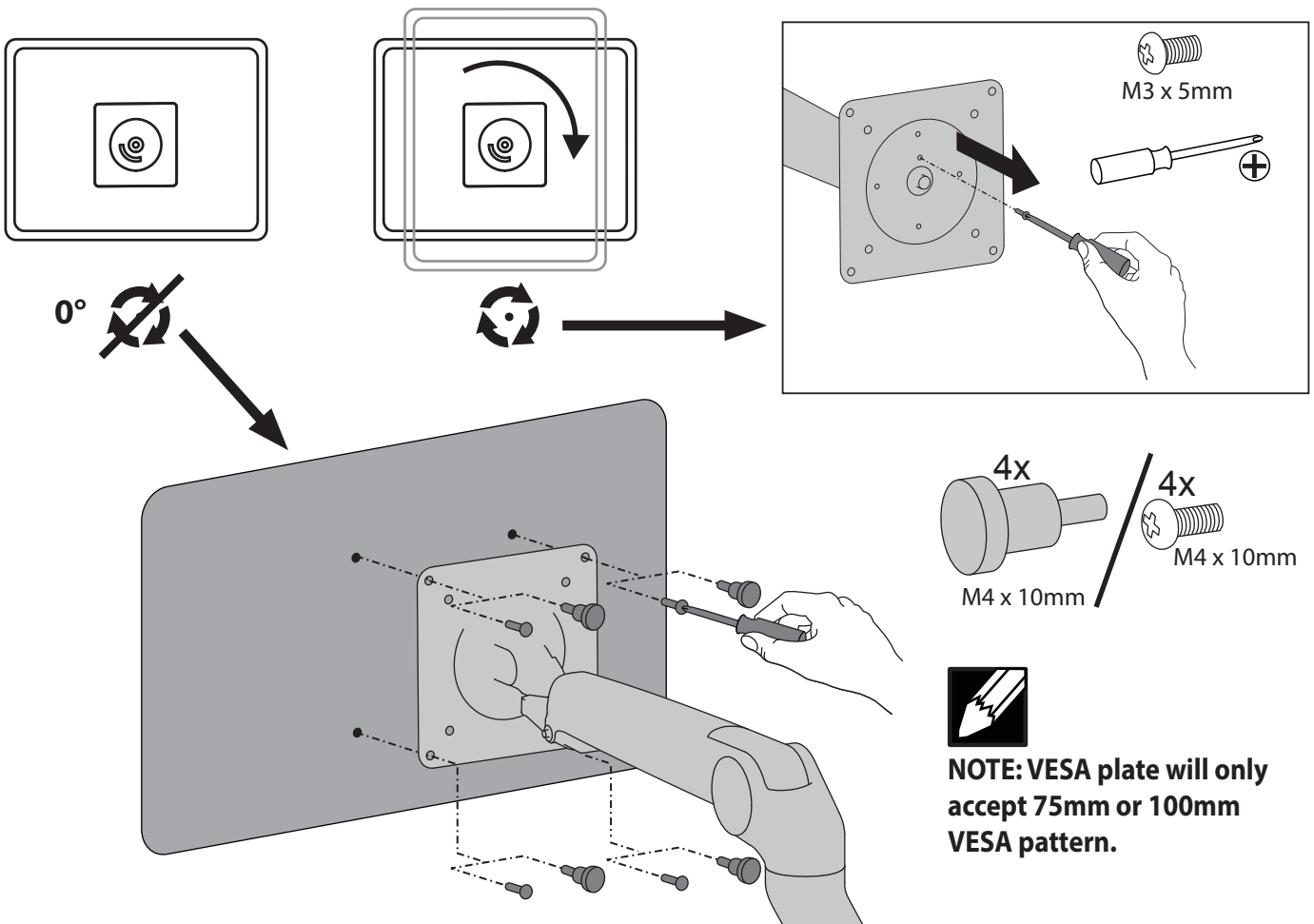

- ## 3
- NOTE: Leave enough slack in cable to allow full range of motion.**
- Caution:** To avoid the potential to pinch cables it is important to follow the cable routing instructions in this manual. Failure to follow these instructions may result in equipment damage or personal injury.

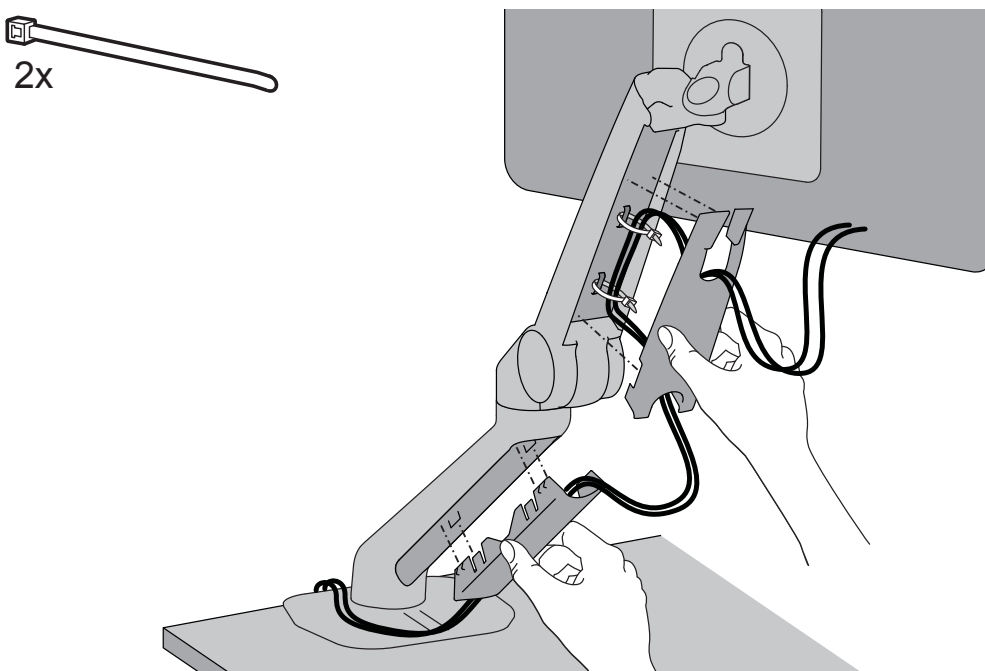



Adjustment Step

You may need to adjust this arm over time as the friction pivot could change tension.

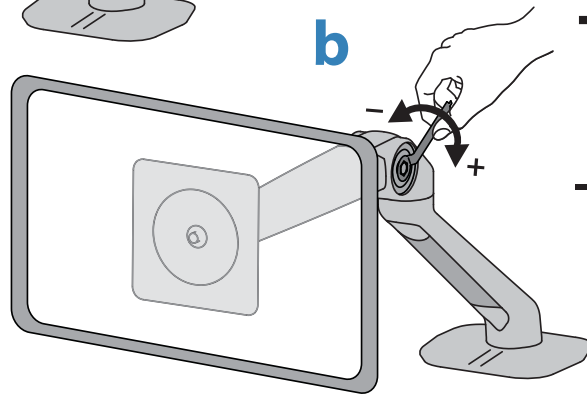
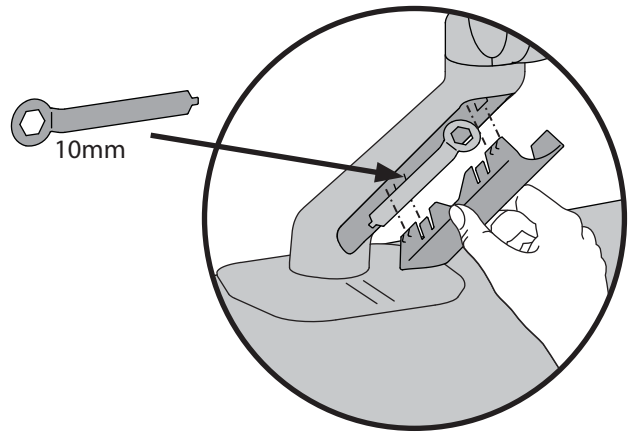
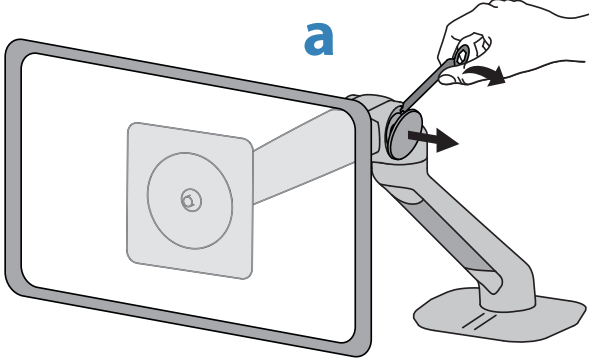
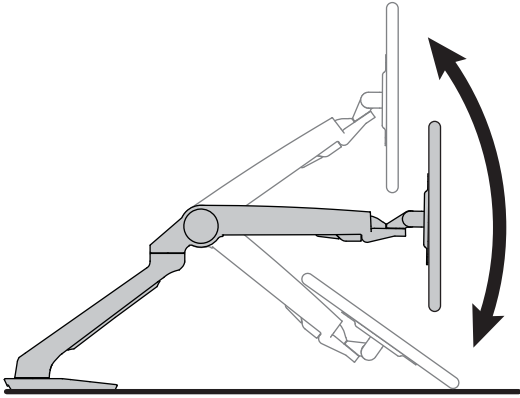

+ Increase Friction
If this product moves too easily, then you'll need to increase friction:

- Decrease Friction
If this product is too difficult to move, then you'll need to decrease friction:

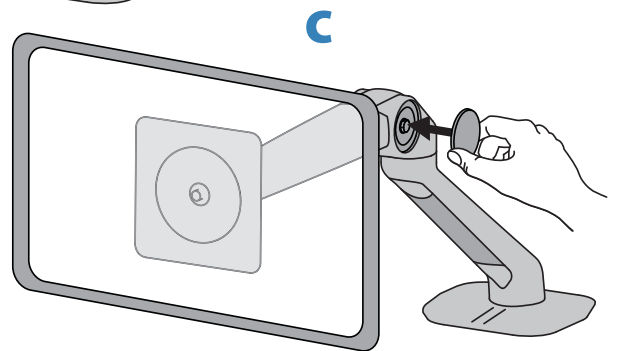

Set Your Workstation to Work For YOU!

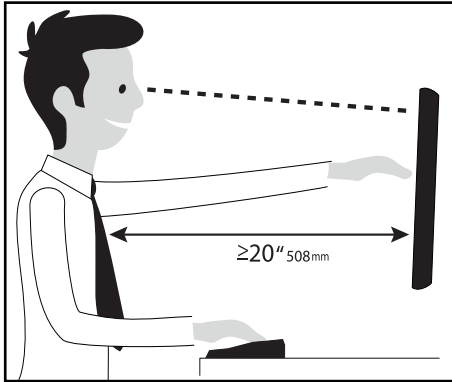

Learn more about ergonomic computer use at:
www.computingcomfort.org

- Height** Position top of screen slightly below eye level.
Position keyboard at about elbow height with wrists flat.
- Distance** Position screen an arm's length from face—at least 20" (508mm).
Position keyboard close enough to create a 90° angle in elbow.
- Angle** Tilt screen to eliminate glare.
Tilt the keyboard back 10° so that your wrists remain flat.

To Reduce Fatigue

- Breathe - Breathe deeply through your nose.
- Blink - Blink often to avoid dry eyes.
- Break • 2 to 3 minutes every 20 minutes
- 15 to 20 minutes every 2 hours.

For Warranty visit: www.ergotron.com/warranty

For Service visit: www.ergotron.com

For local customer care phone numbers visit: <http://contact.ergotron.com>

NOTE: When contacting customer service, reference the serial number.

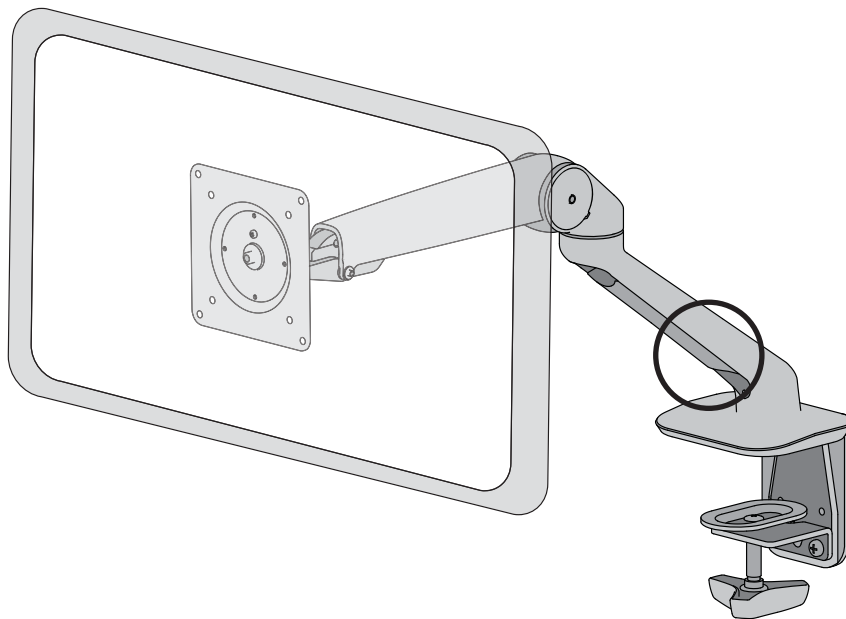

ergotron®

www.ergotron.com | USA: 1-800-888-8458 | Europe: +31 (0)33-45 45 600 | China: 400-120-3051 | Japan: japansupport@ergotron.com

© 2015 Ergotron, Inc. All rights reserved.

While Ergotron, Inc. makes every effort to provide accurate and complete information on the installation and use of its products, it will not be held liable for any editorial errors or omissions (including those made in the process of translation from English to another language), or for incidental, special or consequential damages of any nature resulting from furnishing this instruction and performance of equipment in connection with this instruction. Ergotron, Inc. reserves the right to make changes in the product design and/or product documentation without notification to its users. For the most current product information, or to know if this document is available in languages other than those herein, please contact Ergotron. No part of this publication may be reproduced, stored in a retrieval system, or transmitted in any form or by any means, electronic, mechanical, photocopying, recording or otherwise without the prior written consent of Ergotron, Inc., 1181 Trapp Road, Eagan, Minnesota, 55121, USA Patents Pending and Patented U.S. & Foreign. Ergotron is a registered trademark of Ergotron, Inc.